

# Series-stacked installation drawings

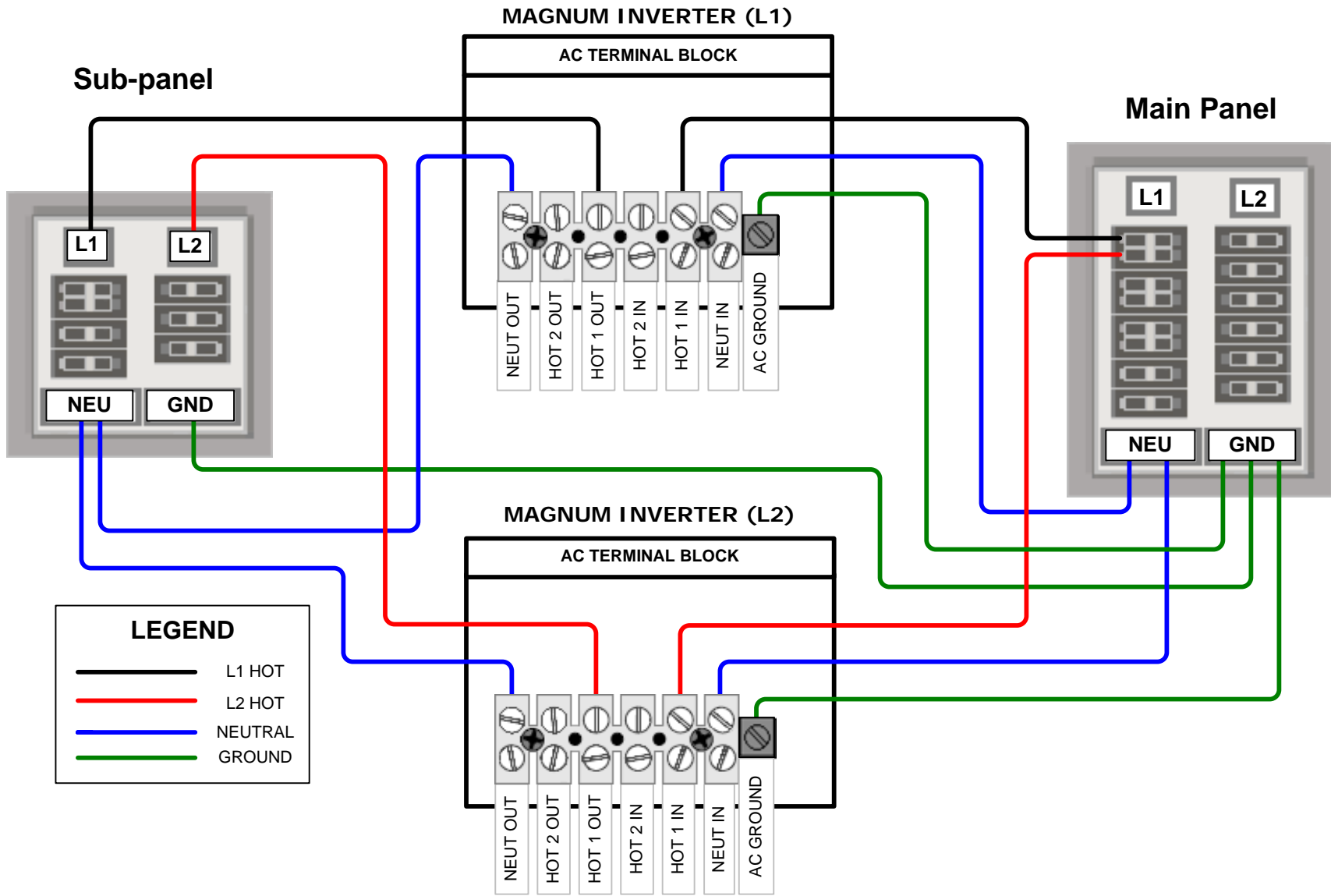

Single In/Single Out (30A with 120/240VAC source)

# Series-stacked installation drawings

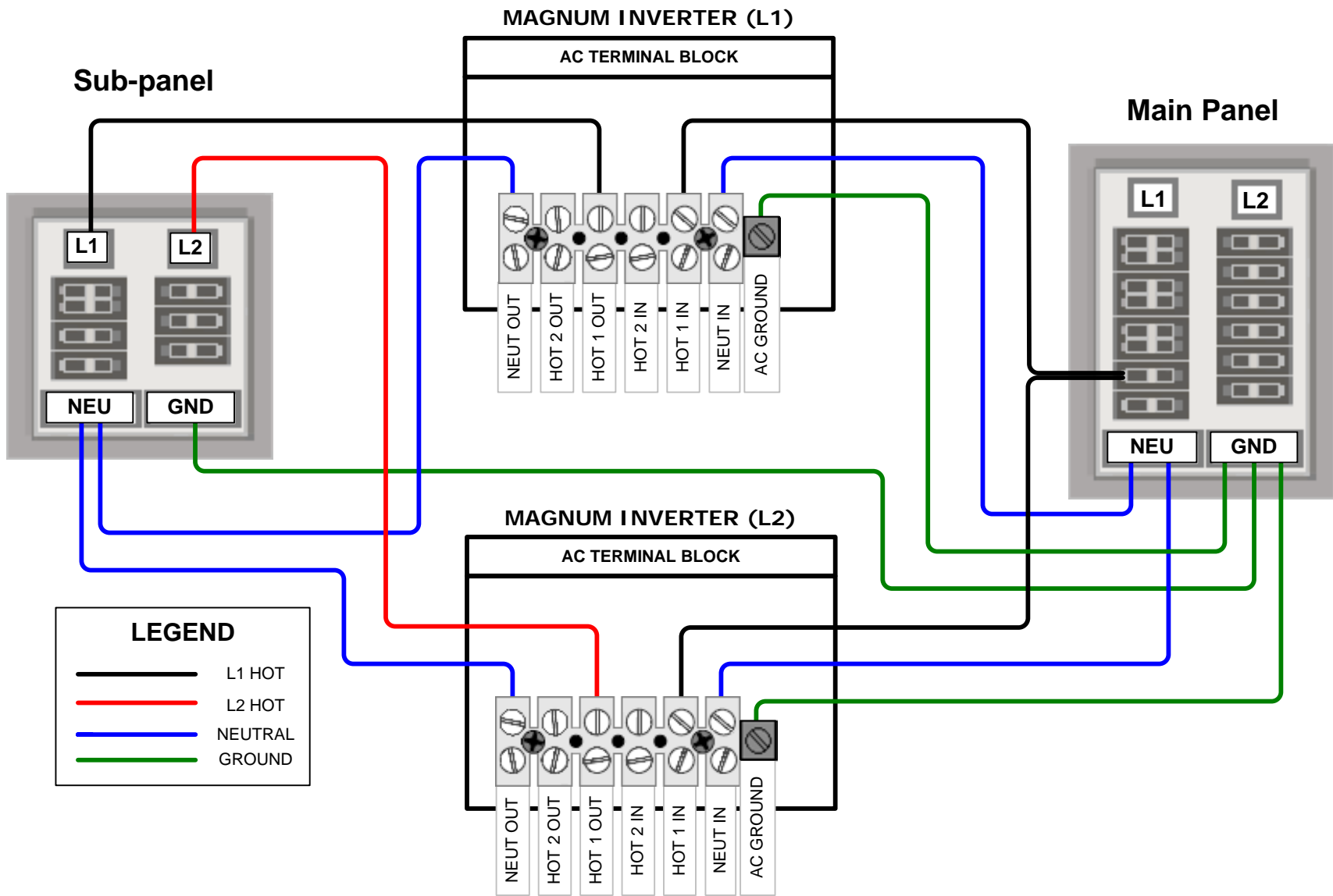

Single In/Single Out (30A with 120VAC source)

# Series-stacked installation drawings

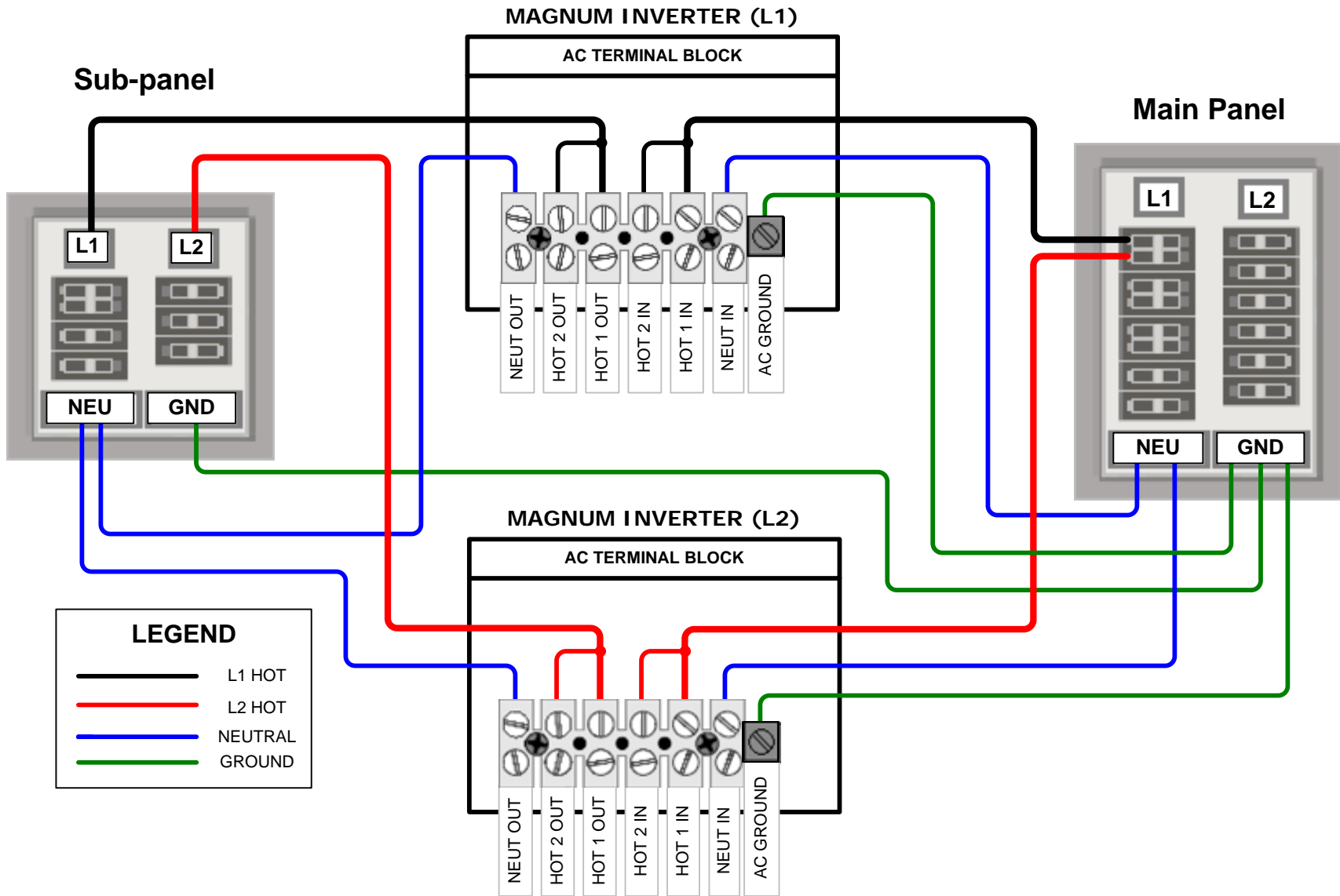

Single In/Single Out (60A with 120/240VAC source)

# Series-stacked installation drawings

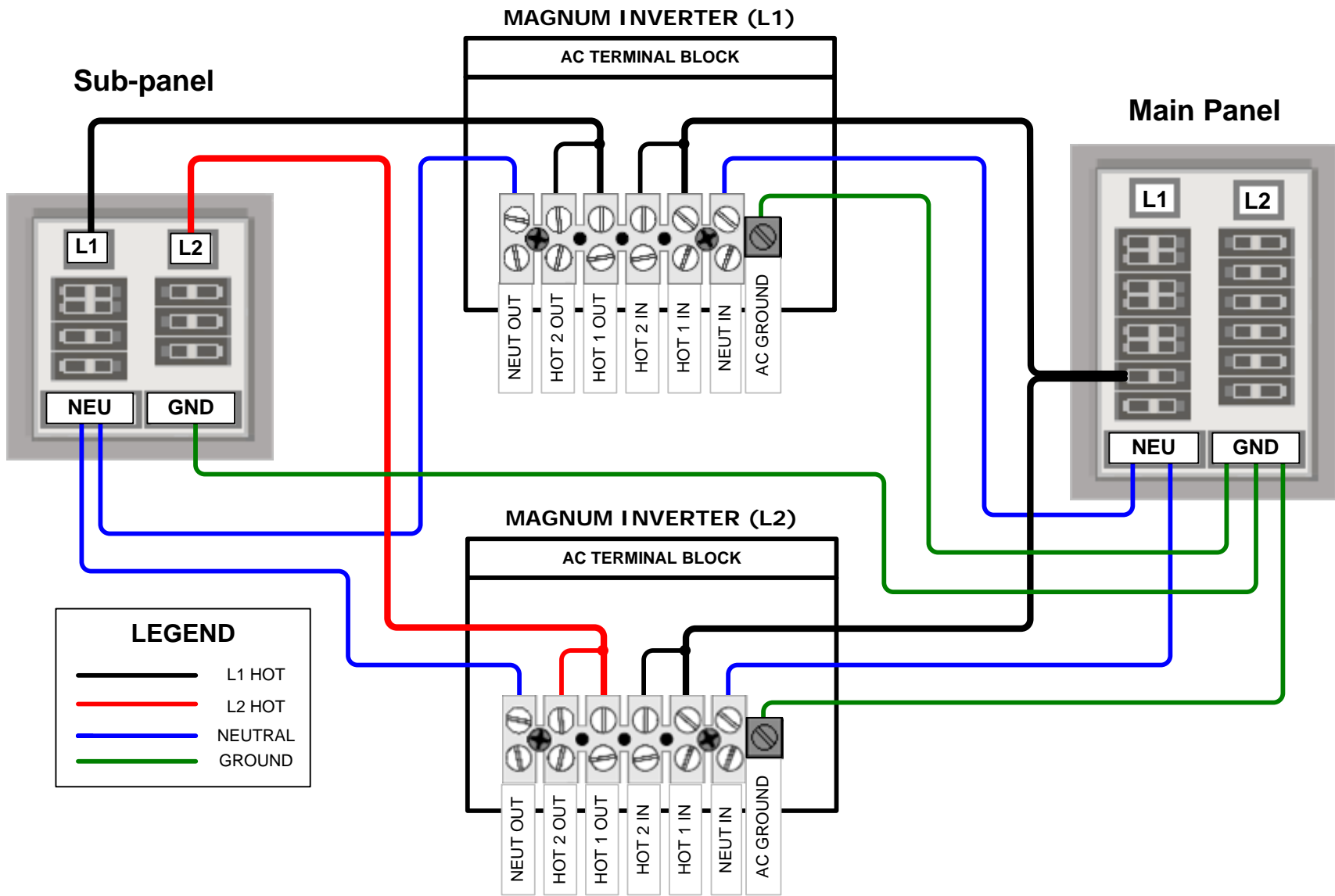

Single In/Single Out (60A with 120VAC source)