

Auto Generator Start wiring diagram – For Honda (EU7000is w/o Remote Switch Gas Generator)

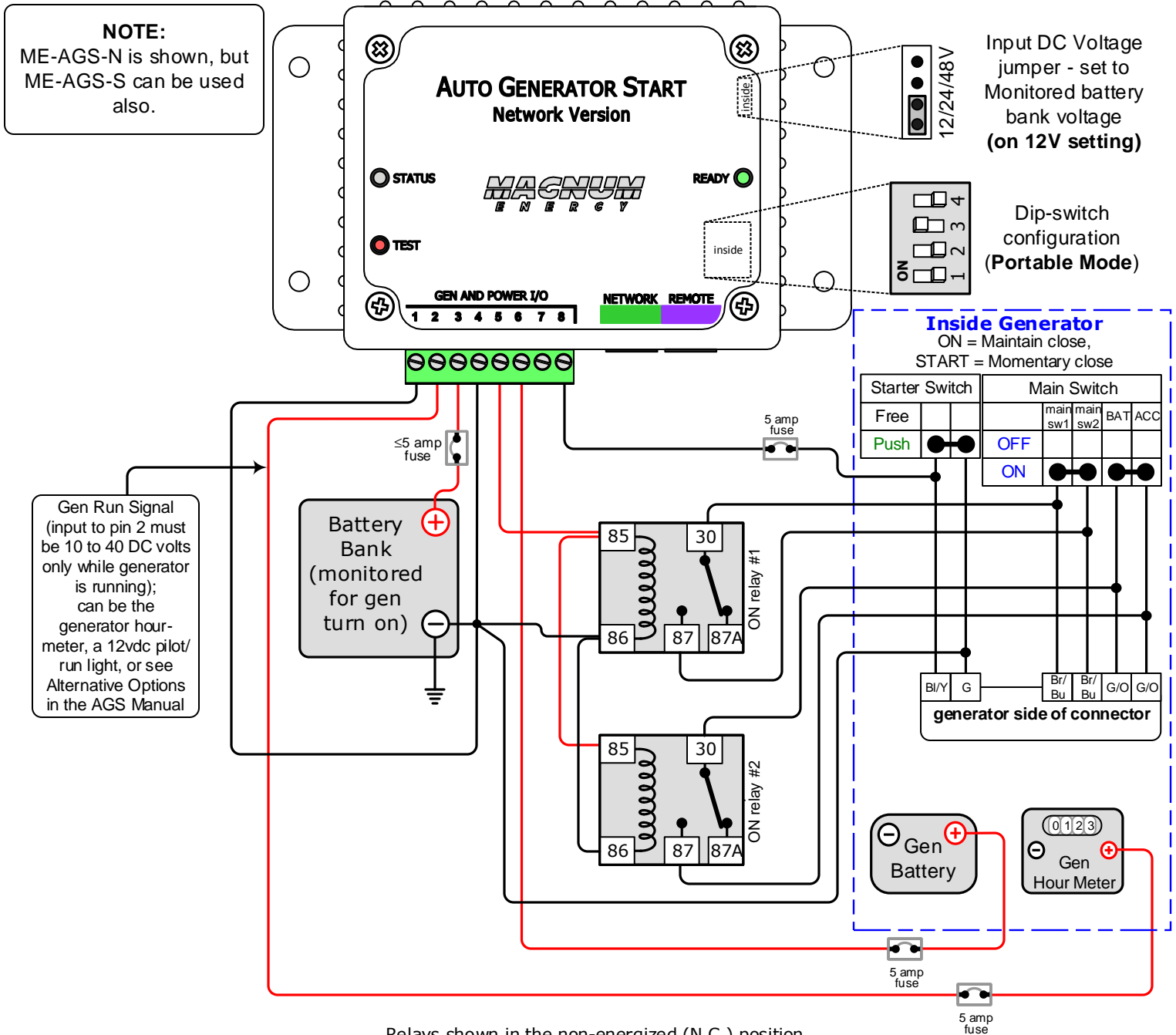

Relays shown in the non-energized (N.C.) position.

ON Relays = SPDT 30 Amp, 12 VDC coil relay; popular in automotive sound and security installations.
Equivalent to Bosch #0 332 209 150 or TYCO #V23234-A1001-X036.

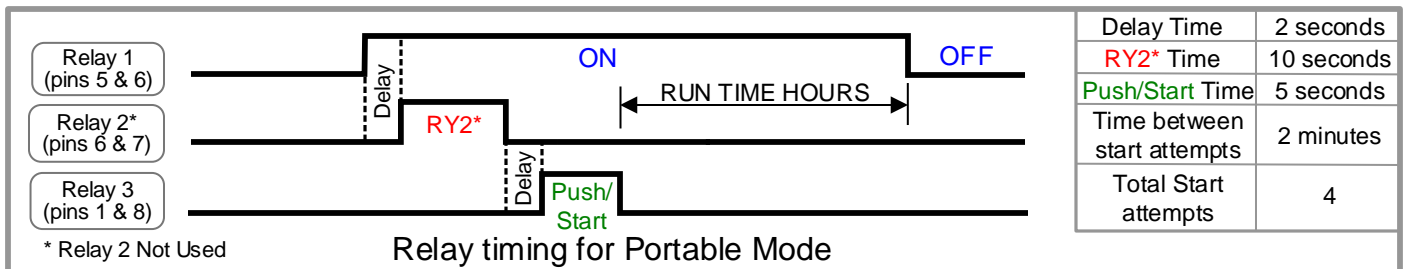

Magnum Energy, Inc. provides this diagram to assist in the installation of the Auto-Generator Start controller. Since the use of this diagram and the conditions or methods of installation, operation and use are beyond the control of Magnum Energy, Inc., we do not assume responsibility and expressly disclaim liability for loss, damage or expense arising out of the installation, operation and use of this unit.