



MMA1212
Modified Sine Wave Inverter/Charger
Owner's Manual

Thank you from all of us at Sensata Technologies for purchasing this MMA1212 inverter/charger. The MMA1212 is a product under the Magnum-Dimensions brand from Sensata Technologies. We understand there are many purchasing options in the marketplace, and are pleased that you have decided on a Magnum product. This product was proudly assembled and tested in the United States.

We are committed to providing quality products and services. We hope your experience with us is pleasant and professional.

Disclaimer of Liability

The use of this manual and the conditions or methods of installation, operation, use, and maintenance of the MMA1212 inverter/charger are beyond the control of Sensata Technologies. Therefore, this company does not assume responsibility and expressly disclaims liability for loss, damage, or expense whether direct, indirect, consequential or incidental that may arise out of or be in any way connected with such installation, operation, use, or maintenance.

Due to continuous improvements and product updates, the images shown in this manual may not exactly match the unit purchased.

Restrictions on Use

The MMA1212 inverter/charger may only be used in life support devices and systems with the express written approval of Sensata Technologies. Failure of this inverter can reasonably be expected to cause failure of that life support device or system, or to affect the safety or effectiveness of that device or system. If the MMA1212 inverter fails, it is reasonable to assume the health of the user or other persons may be endangered.

Copyright Notice

Copyright 2016 by Sensata Technologies. All rights reserved. Permission to copy, distribute, and/or modify this document is prohibited without written permission from Sensata.

Document Information

Description – MMA1212 Owner’s Manual

Part Number and Revision – 64-0072 Rev A

Date Published – April 2016

This entire manual is available for download—with many of the installation diagrams available in color—on our website at: www.Magnum-Dimensions.com.

Contact Information

Sensata Technologies

2211 West Casino Rd.

Everett, WA 98204

Phone: (425) 353-8833 / Fax: (425) 353-8390

Web: www.Magnum-Dimensions.com

Safety Information

Record the unit's model and serial number in case you need to provide this information in the future.

Model:		Serial Number:	
<input type="checkbox"/>	MMA1212	AV	

Conventions used in this Manual

Safety Symbols

To reduce the risk of electrical shock, fire, or other safety hazard, the following safety symbols have been placed throughout this manual to indicate dangerous and important safety instructions.



WARNING: This symbol indicates that failure to take a specified action could result in physical harm to the user.



CAUTION: This symbol indicates that failure to take a specified action could result in damage to the equipment.



Info: This symbol indicates information that emphasizes or supplements important points of the main text.

IMPORTANT PRODUCT SAFETY INSTRUCTIONS

This manual contains important safety instructions that must be followed during the installation and operation of this product. Read all instructions and safety information before installing or using this product.

- All electrical work must be performed in accordance with local, state, and federal electrical codes.
- This product is designed for indoor/compartment installation. DO NOT expose to rain, snow, moisture, or liquids of any type.
- Use insulated tools to reduce the chance of electrical shock or accidental short circuits.
- Remove all jewelry such as rings, watches, bracelets, etc., when installing or performing maintenance on the inverter.
- Always disconnect the batteries or energy source prior to installing or performing maintenance on the inverter. Live power may be present at more than one point since an inverter utilizes both batteries and AC. Turning off the inverter may not reduce this risk. As long as AC power is connected, it will pass through the inverter regardless of the ON/OFF power switch setting.
- Always verify proper wiring prior to starting the inverter.
- Do not operate the inverter if it has been damaged.
- Do not dismantle the inverter; there are no user-serviceable parts contained in this product. Attempting to service the unit yourself could cause electrical shock. Internal capacitors remain charged after all power is disconnected.

Safety Information

- No AC or DC disconnects are provided as an integral part of this inverter. Both AC and DC disconnects must be provided as part of the system installation.
- No overcurrent protection for the battery supply is provided. Overcurrent protection of the battery cables must be provided as part of the system installation.
- No overcurrent protection for the AC output wiring is provided. Overcurrent protection of the AC output wiring must be provided as part of the system installation.

Note: AC overcurrent protection can be provided by the upstream breaker in the main electrical panel.

BATTERY SAFETY INSTRUCTIONS

- Wear eye protection such as safety glasses when working with batteries.
- Remove all jewelry such as rings, watches, bracelets, etc., when installing or performing maintenance on the inverter.
- Never work alone. Always have someone near you when working around batteries.
- Use proper lifting techniques when working with batteries.
- Never use old or untested batteries. Check each battery's label for age, type, and date code to ensure all batteries are identical.
- Batteries are sensitive to changes in temperature. Always install batteries in a stable environment.
- Install batteries in a well-ventilated area. Batteries can produce explosive gasses. For compartment or enclosure installations, always vent batteries to the outside.
- Provide at least one inch of air space between batteries to provide optimum cooling.
- Never smoke when in the vicinity of batteries.
- To prevent a spark at the battery and reduce the chance of explosion, always connect the cables to the batteries first. Then connect the cables to the inverter.
- Use insulated tools at all times.
- Always verify proper polarity and voltage before connecting the batteries to the inverter.
- To reduce the chance of fire or explosion, do not short-circuit the batteries.
- In the event of accidental exposure to battery acid, wash thoroughly with soap and water. In the event of exposure to the eyes, flood them for at least 15 minutes with running water and seek immediate medical attention.
- Recycle old batteries.

SAVE THESE INSTRUCTIONS

Table of Contents

1.0	Introduction	1
1.1	MMA1212 Inverter/Charger	1
1.2	How an Inverter/Charger Works.....	1
1.3	Appliances with a Modified Sine Inverter	2
1.4	Appliances and Run Time	2
1.5	Standard Features and Benefits	2
2.0	Installation	8
2.1	Pre-Installation.....	8
2.2	Locating and Mounting the Inverter.....	10
2.3	DC Wiring	12
2.4	Connecting to the 3-Port Terminal Block.....	18
2.5	Remotes and Connections	19
2.6	Inverter Warning Label	21
2.7	GFCI Breakers.....	21
2.8	Functional Test	23
3.0	Setup	24
3.1	Adjusting DIP Switch Settings.....	24
4.0	Operation	30
4.1	MMA Top Panel Features	30
4.2	Operating Modes	34
4.3	Protection Circuitry Operation.....	37
4.4	Battery Temperature Sensor Operation	39
4.5	Summary of Inverter/DIP Switch Settings	40
5.0	Maintenance & Troubleshooting	41
5.1	Recommended Inverter & Battery Care.....	41
5.2	Troubleshooting	41
5.3	Performing an Inverter Reset.....	44
5.4	Performing a Power Reset	44
6.0	Specifications	45
Appendix A – Optional Equipment & Accessories		46
Appendix B – Battery Information		47
B-1	Battery Bank Sizing.....	47
B-2	Battery Types.....	47
B-3	Battery Configuration	47
Appendix C – Warranty/Service Information		50
C-1	Warranty Information.....	50
C-2	How to Receive Repair Service.....	51

List of Figures

Figure 1-1, MMA1212 Inverter.....	1
Figure 1-2, Top Side Features.....	4
Figure 1-3, Left Side Features	4
Figure 1-4, Right Side Features	5
Figure 1-5, Back Side Features	5
Figure 1-6, Front Side Features	6
Figure 1-7, MMA1212 Inverter's Anderson Connector.....	6
Figure 1-8, Battery Temperature Sensor	7
Figure 2-1, MMA1212 Model Basic Installation Diagram	9
Figure 2-2, Approved Mounting Orientations.....	11
Figure 2-3, MMA1212 Inverter Dimensions.....	12
Figure 2-4, DC Cable to Battery Terminals.....	16
Figure 2-5, MMA1212's 3-Port Terminal Block	18
Figure 2-6, MMA1212 Accessory Connections	20
Figure 2-7, Warning Label.....	21
Figure 3-1, DIP Switch Summary	24
Figure 4-1, Top Panel Power Switch and LED Indicators.....	30
Figure 4-2, Charge Status Indicators.....	31
Figure 4-3, Automatic 4-Stage Charging Graph.....	36
Figure 4-4, Automatic 4-Stage Charging Graph.....	39
Figure 5-1, Resetting the Inverter.....	44
Figure B-1, Series Battery Wiring.....	47
Figure B-2, Parallel Battery Wiring	48
Figure B-3, Series-Parallel Battery Wiring.....	48
Figure B-4, Battery Bank Wiring Examples	49

List of Tables

Table 2-1, Recommended DC Wire/Overcurrent Device	14
Table 3-1, Battery Type to Charge Voltages	28
Table 4-1, Charge Status LED Indicators	31
Table 4-2, Inverter Battery Turn On/Off Levels.....	38
Table 4-3, MMA Inverter/DIP Switch Settings.....	40
Table 5-1, Troubleshooting Guide	42
Table 6-1, MMA1212 Specifications	45

1.0 Introduction

Congratulations on your purchase of an MMA1212 inverter/charger. This product is designed to be powerful, yet simple to use, and will provide you with years of trouble-free use.

Please read this chapter to familiarize yourself with the features and benefits of the MMA1212 inverter/charger.

1.1 MMA1212 Inverter/Charger

The MMA1212 is a 1200-watt inverter/charger with a 20-amp AC transfer relay and a 50-amp, 4-stage PFC charger. AC input is provided by a standard 3 ft. plug-in power cord. Includes isolated input/output neutrals, and a 15' battery temperature sensor.



Figure 1-1, MMA1212 Inverter

1.2 How an Inverter/Charger Works

An inverter takes direct current (DC) from your batteries and turns it into alternating current (AC), like you use at home. The MMA1212 inverter/charger also takes alternating current and transforms it into direct current to recharge your batteries.

There are three modes of operation associated with this inverter:

- **Inverter Mode:** DC from the batteries is transformed into AC for powering your vehicle.
- **Standby Mode:** The unit operates as a battery charger to convert incoming AC power into DC power to recharge the batteries while continuing to pass the incoming AC power directly to the inverter's output—to power any AC loads.

1.2.1 Inverter Applications for Mobile Installations

In mobile applications, an inverter/charger provides power to the AC loads using the energy stored in the batteries and recharges the batteries when shorepower or an onboard generator is available.

1.3 Appliances with a Modified Sine Inverter

Today's inverters come in two basic output waveforms: modified sine (which is actually a modified square wave) and pure sine wave. Modified sine wave inverters approximate a pure sine waveform.

The output of the MMA1212 inverter is a modified sine wave which will run most electronic and household items including but not limited to: TV, VCR, satellite dish receiver, computers, and printers. Some devices such as rechargeable power supplies for phones, drills, and other like devices may not run or may be damaged by modified sine wave inverters.

1.4 Appliances and Run Time

The MMA1212 inverter/charger can power a wide range of household appliances. As with any appliance using batteries for power, there is a certain length of time that it can run—this is called "run time". Actual run time depends on several variables including the size and the type of appliance, the type of batteries installed in your application, as well as the battery's capacity and age. Other factors such as the battery's state of charge and temperature can also affect the length of time your appliances can run.

Depending on your inverter capacity, larger electrical appliances can be used for short durations. However, loads that are used for longer periods such as stoves or water heaters can quickly drain your batteries and are not recommended for inverter applications.

All electrical appliances are rated by the amount of power they consume. The rating is printed on the product's nameplate label, usually located on its chassis near the AC power cord. Even though it is difficult to calculate exactly how long an inverter will run a particular appliance, the best advice is trial and error. Your MMA1212 inverter has a built-in safeguard that automatically protects your batteries from being over-discharged.

1.5 Standard Features and Benefits

The MMA1212 inverter/charger converts 12-volt direct current (VDC) power from your battery to 120-volt alternating current (VAC) power. With the multi-stage battery charger feature, the incoming AC power is optimized using Power Factor Correction (PFC) technology to keep the inverter's battery bank fully charged. The MMA1212 is designed to allow easy installation and use, and its die-cast aluminum baseplate ensures maximum durability and a cooler, more efficient operation.

Introduction

The MMA1212 inverter/charger is equipped with the following:

- 1200 watts continuous at 45°C (113°F)
- Numerous protection features to provide peace-of-mind operation and safe operation
- AC transfer switch circuitry; allowing incoming AC power to continue to pass thru to power loads even if the inverter is off
- Dead battery charging for batteries that are extremely low
- Automatic 4-stage battery charger with power factor correction and temperature compensation—for optimum battery charging (using the temperature sensor)
- DC terminals with Anderson connectors for quick DC connection
- True RMS output voltage regulation to ensure the inverter will deliver the correct amount of power—within the DC input voltage range and the continuous output power level
- Quick connection accessory and remote ports—easily accepts several optional remote controls and the Battery Temp Sensor

1.5.1 External MMA1212 Features

This section covers the many features available on the MMA1212 inverter.

- 1 GFCI Outlet** – a Ground Fault Circuit Interrupter outlet (with test and reset capability).
- 2 Output Circuit Breaker (AC OUT)** – a 15-amp circuit breaker to provide another layer of overload protection. This is not a branch circuit-rated breaker. Separate output breakers may be required on the output.
- 3 Input Circuit Breaker (AC IN)** – a 20-amp circuit breaker to protect the unit's internal wiring and pass-thru relay.
- 4 Auxiliary Output Circuit Breaker (AUX OUT)** – a 20-amp circuit breaker that provides overload protection for the aux DC output.
- 5 Power ON/OFF Switch & LED Status Indicators** – a momentary pushbutton switch that alternately turns the inverter on or off, and five LED status indicators (INV, BULK, ABSORB, FLOAT, and FAULT) for monitoring inverter and charger operation.
- 6 Mounting Flanges (x4)** – two flanges on each side to secure the inverter to a shelf/wall.

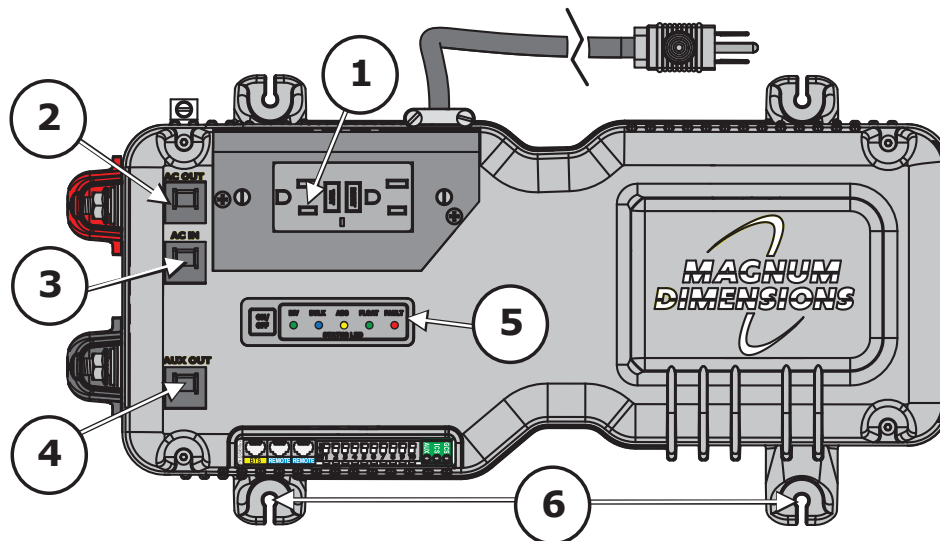

Figure 1-2, Top Side Features

- 7 AC Input Connection** – a strain relief clamp with a 3 ft. standard plug-in power cord to provide AC power to the inverter.
- 8 DC Ground Terminal** – a ground connection used to tie the exposed chassis of the inverter to earth ground, or to the vehicle’s DC grounding system. Terminal accepts CU/AL conductors from #14 to #6 AWG (2.1 mm² to 13.3 mm²).

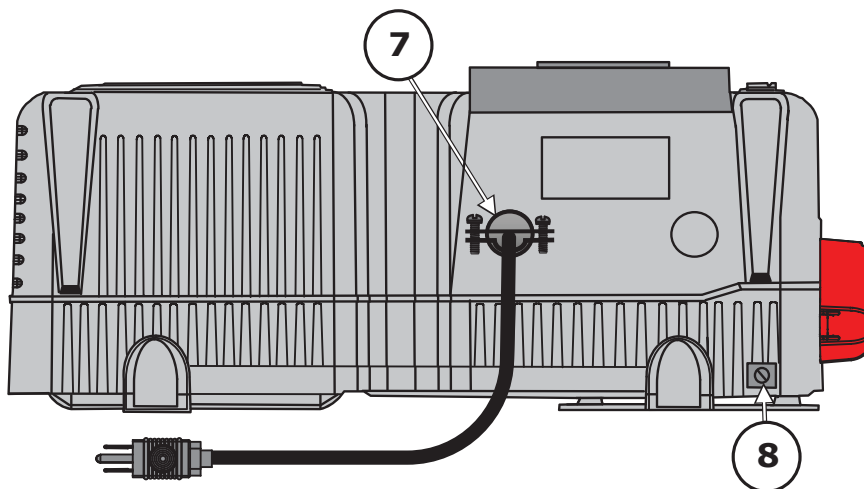

Figure 1-3, Left Side Features

Introduction

- 9 **Battery Temperature Sensor Connection** – a RJ11 port that accepts the supplied remote Battery Temp Sensor (BTS) cable.
- 10 **Remote Connections** – two RJ11 ports for two remotes (i.e., remote control & remote monitor) to be connected for adjusting/monitoring inverter and charger operation.
- 11 **Dual In-line Package (DIP) Switch** – 10 individual slide switches that are used to determine the MMA inverter/charger’s operating parameters.
- 12 **3-Port Terminal Block** – three spring-loaded clip terminals to connect an optional 20-amp DC auxillary device, a ignition control switch, and a ground remote control switch.

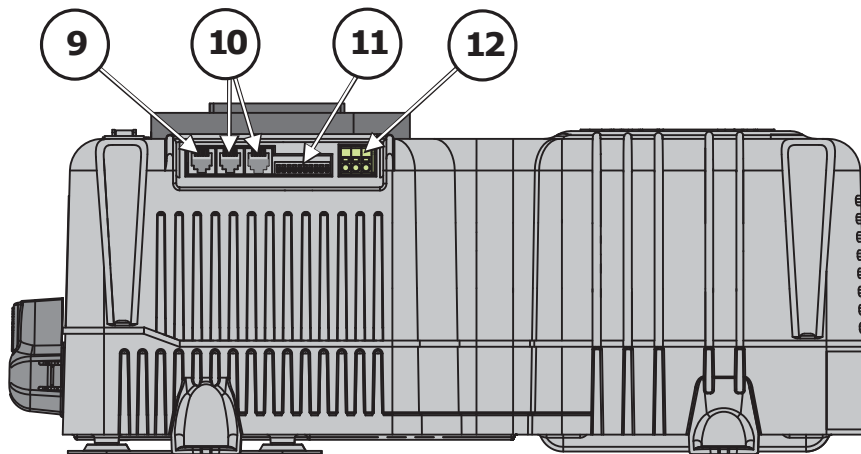

Figure 1-4, Right Side Features

- 13 **Exhaust Vent** – ventilation openings that allow heated air to be removed by the internal cooling fan.
- 14 **Model/Serial Number Label** – includes model/serial number and provides specifications and information on the inverter and charger.

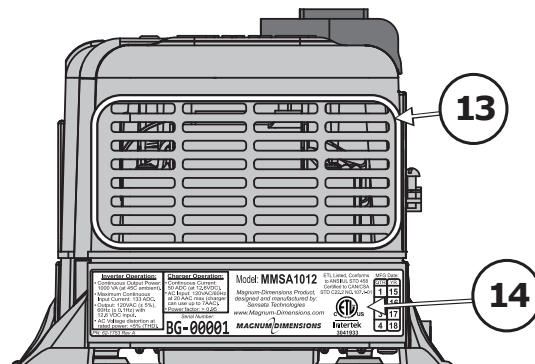

Figure 1-5, Back Side Features

- 15 **Warning and Information Label** – provides pertinent information for safely using the inverter.
- 16 **Positive DC Terminal** – the inverter’s connection to the positive terminal on the battery bank. The MMA1212 comes with one end of a red #2 AWG DC cable already connected to the inverter’s positive terminal (Figure 1-6), and the other end with an Anderson connector (SB175) attached (Figure 1-7).
- 17 **Negative DC Terminal** – the inverter’s connection to the negative terminal on the battery bank. The MMA1212 comes with one end of a black #2 AWG DC cable already connected to the inverter’s negative terminal (Figure 1-6), and the other end with an Anderson connector (SB175) attached (Figure 1-7).
- 18 **Intake Vent** – ventilation openings to pull in air to help keep the inverter cool for peak performance.

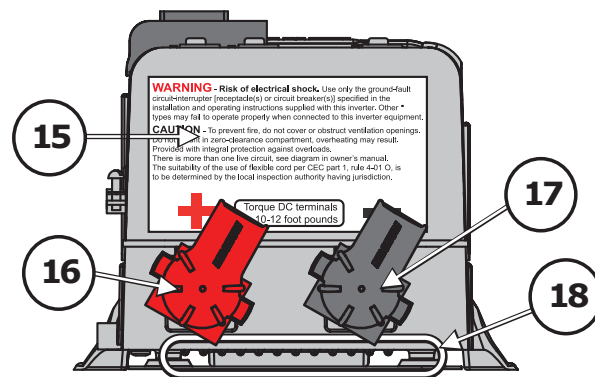

Figure 1-6, Front Side Features

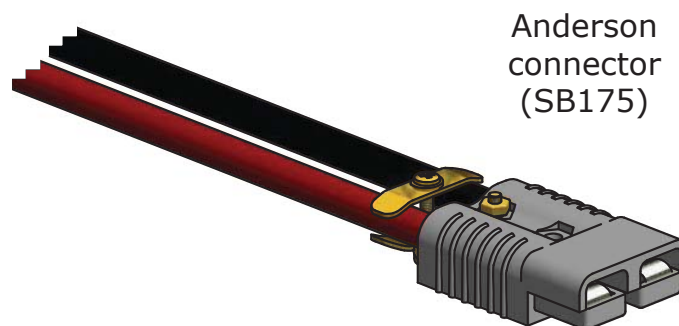

Figure 1-7, MMA1212 Inverter’s Anderson Connector

Introduction

1.5.2 Battery Temperature Sensor

A plug-in external Battery Temperature Sensor (BTS) is provided (Figure 1-8). When installed, the BTS automatically adjusts the battery charger's BULK, ABSORB, and FLOAT voltage set-points based on temperature for better charging performance and longer battery life. If the temperature sensor is not installed and the batteries are subjected to large temperature changes, the battery life may be shortened.

The BTS cable comes with a RJ11 connector that plugs into the BTS port on the side of the inverter (Figure 1-4, Item 9). Refer to Figure 2-4 for installation instructions, and to Section 4.4 for information on the operation of the BTS.

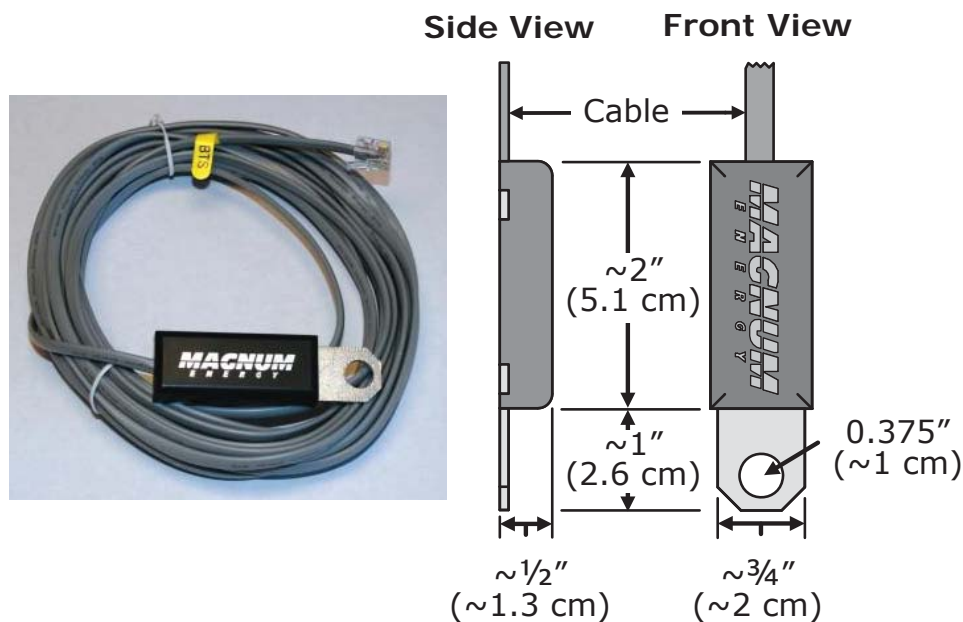

Figure 1-8, Battery Temperature Sensor

2.0 Installation

2.1 Pre-Installation

Before installing the inverter, read the entire Installation section. The more thorough you plan in the beginning, the better your inverter needs will be met.



WARNING: Installations should be performed by qualified personnel, such as a licensed or certified electrician. It is the installer's responsibility to determine which safety codes apply and to ensure that all applicable installation requirements are followed. Applicable installation codes vary depending on the specific location and application of the installation.



Info: Review the safety information on pages ii-iii before proceeding with your installation.

The basic system diagram shown in Figure 2-1 should be reviewed to assist you in planning and designing your installation.

2.1.1 Unpacking and Inspection

Carefully remove the MMA1212 inverter from its shipping container and inspect all contents. Verify the following items are included:

- MMA1212 inverter/charger
- Connected positive and negative battery cables with Anderson connector attached
- Battery Temperature Sensor
- MMA1212 Owner's Manual
- Warning label

If items appear to be missing or damaged, contact your authorized dealer or Sensata.

If at all possible, keep your shipping box. It will help protect your inverter from damage if it ever needs to be returned for service.

Save your proof-of-purchase as a record of your ownership; it will also be needed if the unit should require in-warranty service.

Record the unit's model and serial number in the front of this manual in case you need to provide this information in the future. It is much easier to record this information now, instead of trying to gather it after the unit has been installed.

Installation

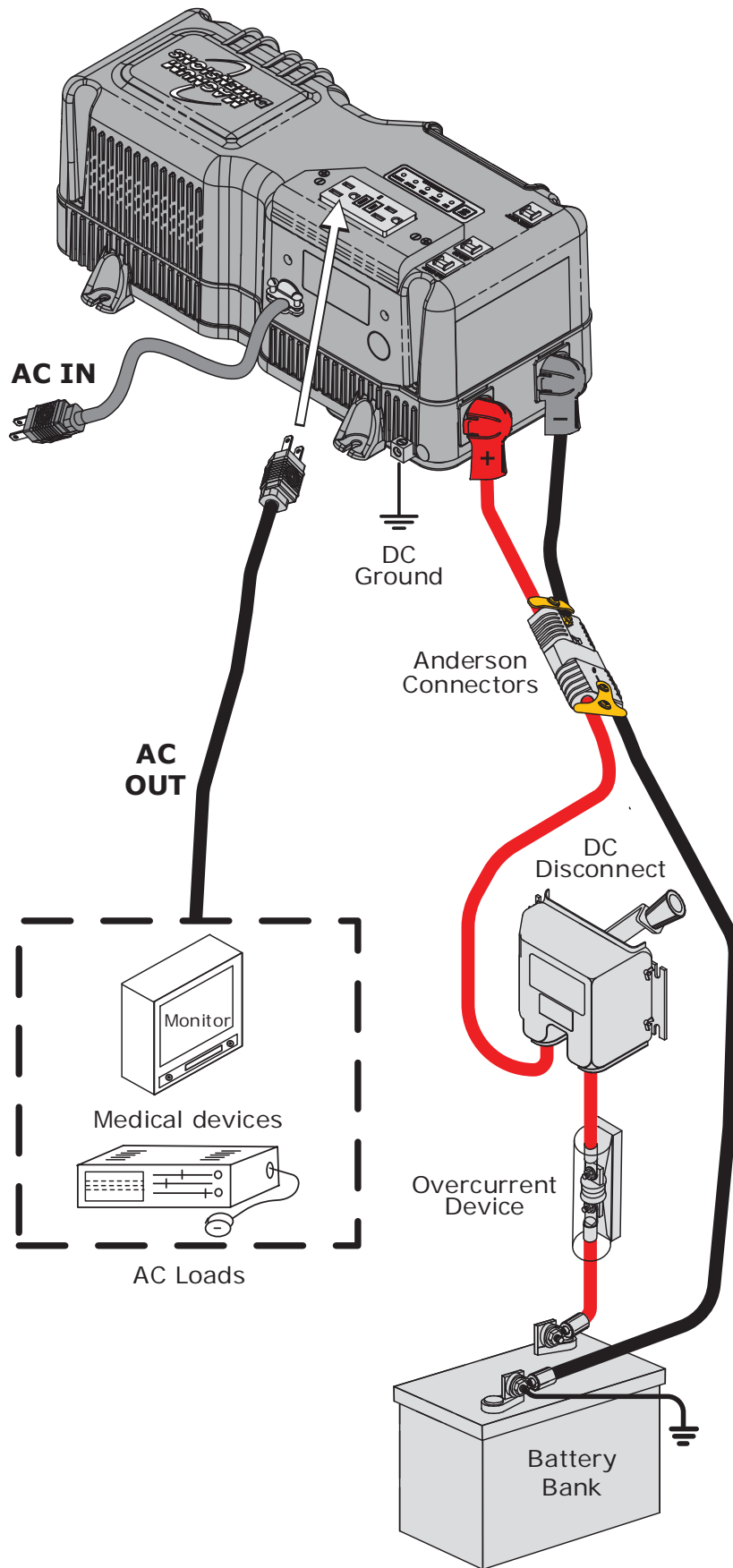

Figure 2-1, MMA1212 Model Basic Installation Diagram

2.2 Locating and Mounting the Inverter



WARNINGS:

- Do not mount the inverter near any flammable or combustible fluid or components.
- Provide adequate clearance/ventilation to the inverter.
- Mount only on a “non-combustible” surface.
- Maximum ambient temperature around the inverter must not exceed 113°F (45°C) to meet power specifications.

The inverter should only be installed in a location that meets the following requirements:

Clean and Dry – The inverter should not be installed in an area that allows dust, fumes, insects, or rodents to enter or block the inverter’s ventilation openings. This area also must be free from any risk of condensation, water, or any other liquid that can enter or fall on the inverter. The inverter uses stainless steel fasteners, plated copper busbars, and a power-coated aluminum base. Also, the internal circuit boards are conformal coated. The above measures are undertaken to help fight the harmful effects of corrosive environments. However, the life of the inverter is uncertain if used in any of these types of environments, and inverter failure under these conditions is not covered under warranty.

Cool – The inverter is rated for indoor use only and should be protected from direct exposure to the sun or to any equipment that produces extreme heat. The ambient air temperature should be between -4°F and 140°F (-20°C to 60°C); realize that the inverter’s continuous output power and continuous charger current are rated at 113°F (45°C), so the cooler the better within this range.

Ventilated – In order for the inverter to provide full output power and avoid over-temperature fault conditions, do not cover or block the inverter’s ventilation openings and ensure there is enough space to allow heated air inside the inverter to escape. Provide as much clearance around the inverter’s intake and exhaust ventilation openings as possible (Figure 1-5, Item 13 and Figure 1-6, Item 18). If installed in an enclosure, a fresh air intake opening is recommended to allow cool air from the outside to flow into the inverter and heated air to exit away from the inverter and the enclosure.

Safe – Keep flammable/combustible materials (e.g., paper, cloth, plastic, etc.) that may be ignited by heat, sparks, or flames at a minimum distance of 2 feet (60 cm) away from the inverter. Do not install this inverter in an area that contains extremely flammable liquids like gasoline or propane, or in locations that require ignition-protected devices.

Installation

Close to the battery bank – As with any inverter, it should be located as close to the batteries as possible. Long DC wires tend to lose efficiency and reduce the overall performance of an inverter. However, the unit should not be installed in the same compartment as the batteries or mounted where it will be exposed to gases produced by the batteries. These gases are corrosive and will damage the inverter; also, if these gases are not ventilated and allowed to collect, they could ignite and cause an explosion.

Accessible – Do not block access to the inverter's remote and accessory ports. Also, allow enough room to access the DC wiring connections as they will need to be checked and tightened periodically. See Figure 2-3 for the MMA's dimensions.

Mounting Orientation – To meet regulatory requirements, the MMA1212 inverter/charger can only be mounted on a horizontal surface (right-side up or up-side down on a shelf/table) or vertical surface (right-side up on a wall/bulkhead), as shown in Figure 2-2. The inverter must be mounted on a "non-combustible" surface, and this surface and the mounting hardware must be capable of supporting at least twice the weight of the inverter. After determining your mounting position, use the base of the inverter's chassis as a template to mark your mounting screw locations. Remove the inverter and drill pilot holes into the mounting surface.

As this unit is used in a mobile application, you may want to place flexible washers or bushings between the mounting surface and the inverter's mounting flanges to reduce vibration.

Once the inverter has been properly mounted, you can begin to wire the DC connections.

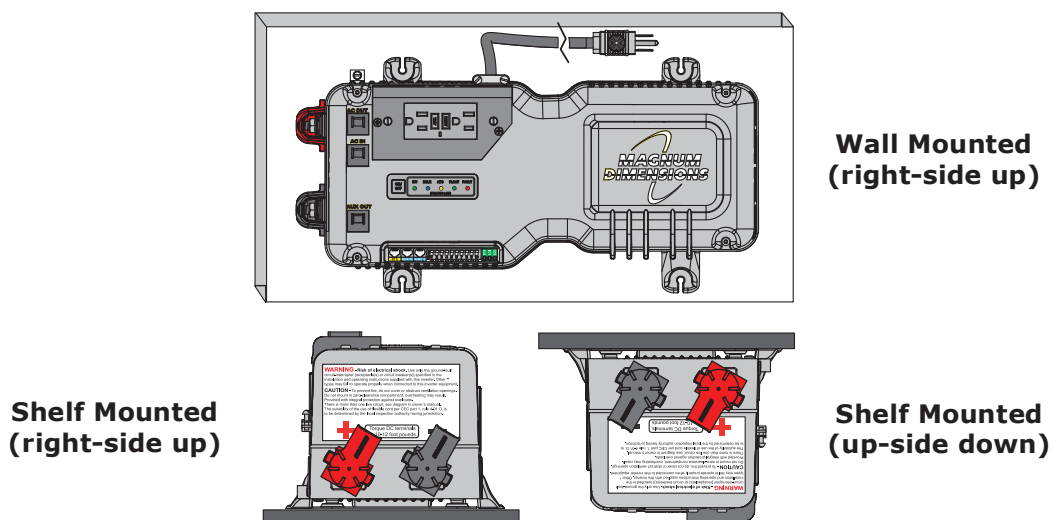

Figure 2-2, Approved Mounting Orientations

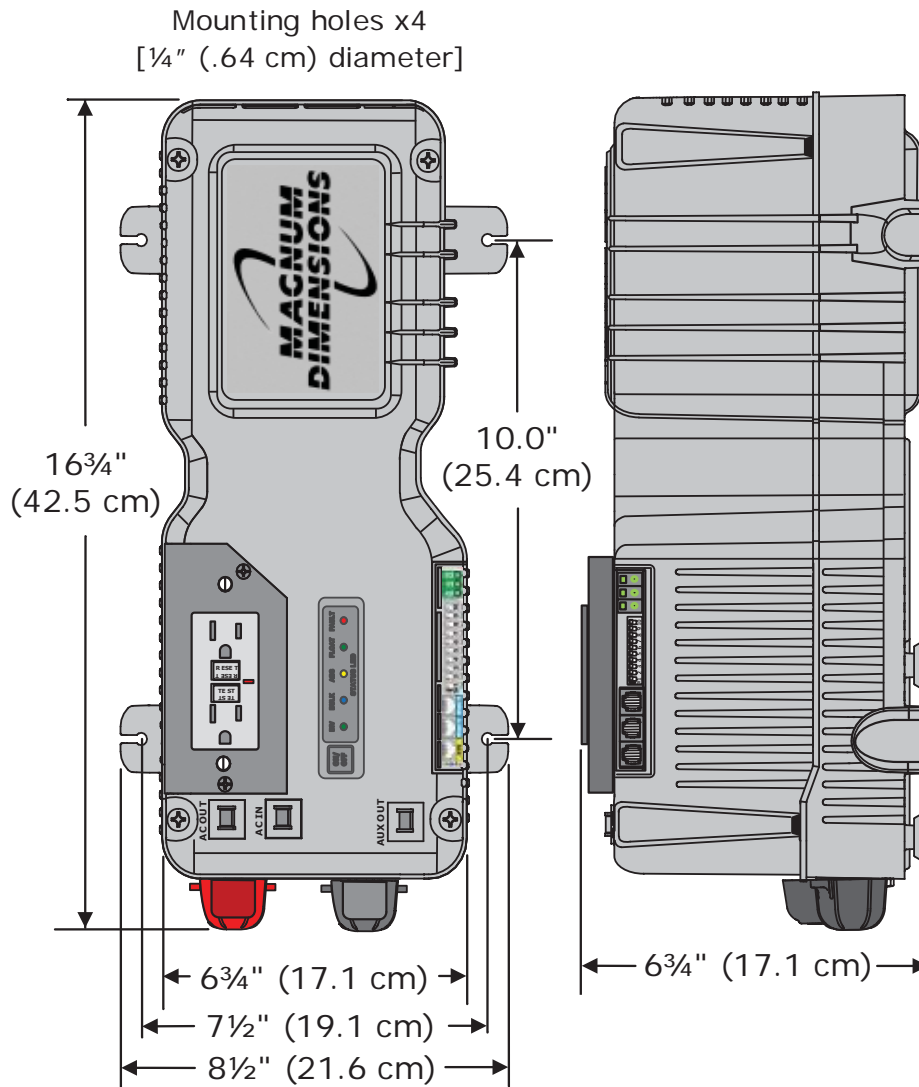

Figure 2-3, MMA1212 Inverter Dimensions

2.3 DC Wiring

This section describes the inverter's required DC wire sizes, the recommended disconnect/overcurrent protection, and how to make the DC connections to the inverter and the battery bank.



WARNING: Even though DC voltage can be regarded as "low voltage", significant hazards may be present, particularly from short circuits of the battery system.



CAUTION: The inverter is NOT reverse polarity protected—which means if the negative and positive battery voltage is connected to the inverter backwards, the inverter will likely be damaged. Use a voltmeter to verify the correct polarity BEFORE connecting the DC wires.



CAUTION: DO NOT connect the battery cables to the inverter until all wiring is complete and the correct DC voltage and polarity have been verified.

Installation

Refer to Figure 2-4 when connecting the DC wires to the battery. Also, consider the following requirements to ensure maximum performance:

- The DC positive and negative cables connected to the inverter from the battery bank should be tied together with wire ties/straps or electrical tape approximately every 6 inches (15.3 cm). This helps improve the surge capability and reduces the effects of inductance, which improves the inverter waveform and reduces the wear of the inverter's filter capacitors. Keeping the battery cables close together also reduces the chance of radio frequency interference.
- Make sure cables have a smooth bend radius and do not become kinked. Follow existing wire runs where possible.
- The battery bank voltage **MUST** be between 9.0 and 16.0 volts for the inverter to operate. If the voltage exceeds 16.0V, the inverter may be damaged.
- To ensure the maximum performance from the inverter, all connections from the battery bank to the inverter should be minimized. The exceptions are the DC fuse and disconnect, or the DC circuit breaker—required at the battery to protect the DC wiring—in the positive line. Any other additional connection will contribute to additional voltage drops, and these extra connection points may loosen during use.
- A brief spark or arc may occur when connecting the battery cables to the inverter DC terminals; this is normal and due to the inverter's internal capacitors being charged.
- Before routing the wiring, color code the DC cables/wires to the battery bank with colored tape or heat shrink tubing: RED for positive (+), WHITE for negative (-), and GREEN (or bare copper) for DC ground, to avoid polarity problems.
- A cable should be connected directly from the inverter negative terminal to the battery negative connection; this ensures the inverter has a reliable return path directly to the battery. Do not use the chassis in place of the battery negative connection to the inverter.

2.3.1 DC Wire Sizing

It is important to use the correct sized DC wire to achieve maximum efficiency from the system and to reduce fire hazards associated with overheating. Always keep wire runs as short as practical to prevent low voltage shutdowns and to keep the DC breaker from nuisance tripping (or open fuses) because of increased current draw. See Table 2-1 to select the minimum DC wire size (and corresponding overcurrent device) required based on your inverter model. The cable sizes listed in this table are required in order to reduce stress on the inverter, minimize voltage drops, increase system efficiency, and ensure the inverter's ability to surge heavy loads.

If the distance from the inverter to the battery is >5 feet (1.5 m), the DC wire will need to be increased. Longer cable distances affect the performance of the inverter. See the lower part of Table 2-1 to determine the minimum DC wire size needed for various distances greater than 5 feet—based on your inverter model.

DC Wire Size Exception: In an OEM RV application, smaller DC wire (with appropriate overcurrent protection) may be used if the inverter will only be connected to a dedicated load, and the inverter and dedicated load have been thoroughly tested and sold together by the OEM as a complete system.

Table 2-1, Recommended DC Wire/Overcurrent Device

		Inverter Model
		MMA1212
Maximum Continuous Current¹		160 amps
DC Grounding Electrode Wire Size²		#8 AWG (8.36 mm ²)
Minimum DC Wire Size³ (75°C rating in free air)		#1 AWG (42.4 mm ²) 195 amps
Maximum DC Fuse Size⁴		175 amps with time delay
Increased size for longer distance	5 to 10 feet =	#1 AWG (42.4 mm ²)
	10 to 15 feet =	#1/0 AWG (53.5 mm ²)

Note¹ – Max continuous current is based on the inverter’s continuous power rating at the lowest input voltage with an inefficiency factor.

Note² – The grounding conductor for the DC system shall meet the sizing requirements specified in the NEC for the application, but must be no smaller than 8 AWG (8.36 mm²) copper. In some applications (i.e., Marine installations), the DC grounding conductor is required to be no less than one size smaller than the wire size of the DC positive/negative cables.

Note³ – Wire size is based on the requirements needed to increase efficiency and reduce stress to the inverter.

Note⁴ – The next larger standard size overcurrent device may be used if the de-rated cable ampacity falls between the standard overcurrent devices found in the NEC.

2.3.2 DC Overcurrent Protection

For safety reasons and to comply with electrical code regulations, DC overcurrent protection must be provided as part of the installation. The DC overcurrent protection device must be installed in the

Installation

positive DC cable line, it can be a fuse (with disconnect switch) or a circuit breaker and must be DC-rated. It must be correctly sized according to the size of DC cables being used, which means it is required to open before the cable reaches its maximum current carrying capability, thereby preventing a fire. The NEC requires both overcurrent protection and a disconnect switch.

Because batteries can deliver thousands of amps in an instant during a short, you are required to install a DC-rated fuse (or circuit breaker) that has a interrupt current rating (known as Amps Interrupting Current, or AIC) that can withstand the short-circuit current without explosion or damage. If a fuse is used as an overcurrent device, a Class-T type or equivalent is highly recommended when used with inverters. A Class-T fuse is rated for DC operation, can handle very high short-circuit currents (up to 100,000 amps), and has a time delay that allows for momentary current surges from the inverter without opening the fuse. In some installations, if the combined short-circuit current of all the batteries in the bank is determined to be 2,700 amps or less, then an ANL type of fuse may be used—if in doubt, use a Class-T fuse. See Table 2-1 for the fuse size (coordinated with the DC wire size) recommended for your inverter.

2.3.3 DC Grounding

The inverter should always be connected to a permanent, grounded wiring system. The idea is to connect the metallic chassis of the various enclosures together to have them at the same voltage potential, to reduce the possibility for electric shock. For most installations, the inverter chassis and the negative battery conductor are connected to the system's ground bond via a safety grounding conductor (bare wire or green insulated wire) at only one point in the system. The grounding conductor for the DC system shall meet the sizing requirements specified in the NEC for the application, but must be no smaller than #8 AWG copper. *For instance, an inverter used in a marine application under ABYC guidelines requires the size of the DC grounding conductor to be of an ampacity equal to or one size less than that of the DC positive conductor.* See Table 2-1 for the minimum ground wire size recommended for your inverter.



Info: If the inverter is installed in a vehicle, connect the battery negative cable directly to the inverter's negative terminal. DO NOT connect the negative battery cable meant for the inverter to the vehicle's frame/safety ground.

2.3.4 DC Cable Connections

Do not put anything between the battery cable ring lug and the battery post (see Figure 2-4). When connecting the battery cable, it should be placed directly against the battery post. Incorrectly installed hardware causes a high resistance connection which could lead to poor inverter performance, and may melt the cable and terminal connections. Torque from 10 to 12 ft-lbs.

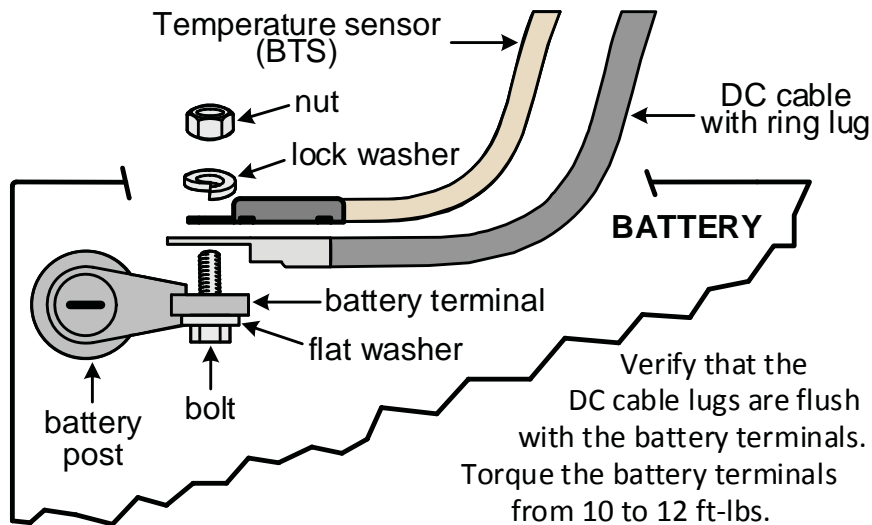

Figure 2-4, DC Cable to Battery Terminals

2.3.5 Battery Bank Wiring



WARNING: Lethal currents will be present if the positive and negative cables attached to the battery bank touch each other. During the installation and wiring process, ensure the cable ends are insulated or covered to prevent touching/shorting the cables.



Info: DO NOT connect the DC wires from the battery bank to the inverter until: 1) all DC wiring complete, 2) the correct DC and AC overcurrent protection have been installed, and 3) the correct DC voltage and polarity have been verified.



Info: For optimum performance, a minimum battery bank of 200 AH is recommended.

Depending upon the type of batteries you use in the installation (6 or 12 VDC), the batteries must be wired in series, parallel, or series-parallel to provide 12 VDC (see Appendix B – Battery Information, for guidance on wiring batteries together). The interconnecting DC wires must be sized and rated exactly the same as those that are used between the battery bank and the inverter.

Place the batteries as close as practical to the inverter, preferably in an insulated and ventilated enclosure. Allow adequate space above the batteries to access the terminals and vent caps (as applicable). Allow $\geq 1"$ (2.5 cm) of space between the batteries to provide good air flow. DO NOT mount the batteries directly under the inverter.



Info: To ensure the best performance from your inverter system do not use old or untested batteries. Batteries should be of the same size, type, rating, and age.

Installation



CAUTION: Install batteries in a well-ventilated area. Batteries can produce explosive gasses. For compartment or enclosure installations, always vent batteries to the outside.

2.3.6 Inverter to Battery Bank Wiring



WARNING: Ensure all sources of DC power (i.e., batteries) and AC power (utility/shorepower or AC generator) are de-energized (i.e., breakers opened, fuses removed) before proceeding.



CAUTION: The inverter is NOT reverse polarity protected. If this happens, the inverter will be damaged and will not be covered under warranty. Before connecting the DC wires from the batteries to the inverter, verify the correct battery voltage and polarity using a voltmeter. If the positive terminal of the battery is connected to the negative terminal of the inverter and vice versa, severe damage will result. If necessary, color code the cables with colored tape or heat shrink tubing—RED for positive (+) and BLACK for negative (–) to avoid polarity confusion.



Info: The DC overcurrent device (i.e., fuse/circuit breaker) must be placed in the positive (RED) DC cable line between the inverter's positive DC terminal and the battery's positive terminal (RED)—as close to the battery as possible.

DC Ground Wire

Route an appropriately sized DC grounding wire (GREEN or bare wire) from the inverter's DC Ground Terminal (Figure 1-3, Item 8) to a dedicated system ground. Torque to 45 in-lbs.

2.3.6.1 Wiring the Battery Bank to a MMA1212 Inverter

Use the following information to safely connect the MMA1212 inverter to your battery bank. Refer to Figure 2-1 before proceeding.

Inverter's DC Positive and Negative Wires

The MMA1212 inverter comes with the positive and negative DC battery cables secured to the unit (and the red/black terminal covers in place). The DC cables have an attached Anderson connector.

Important: *You must supply a compatible Anderson connector (see Figure 1-7) for the battery bank DC cable side (per Figure 2-1).*

Battery Bank's DC Positive Wire

1. Mount the DC fuse block (or circuit breaker assembly) and DC disconnect as near as practical to the batteries, and then remove the fuse (or open the circuit breaker).



WARNING: DO NOT close the DC fuse/disconnect (or close the DC circuit breaker) to enable battery power to the inverter at this time. Wait for the **Functional Test**.

2. Connect a short wire (same rating as the DC wires) from one end of the fuse block to the positive terminal of the first battery string (see Figure B-3).
3. Connect another short wire (same rating as the DC wires) from the other end of the fuse block to one end of the DC disconnect.
4. Using a compatible Anderson connector (not supplied), route and connect its appropriately sized DC positive wire (RED) to the other end of the DC disconnect.

Battery Bank's DC Negative Wire

5. Route and connect the appropriately sized DC negative wire (BLACK) from the Anderson connector you supplied (Step 4) to the negative terminal of the last battery string. This ensures even charging and discharging across the entire battery bank.

Battery Temperature Sensor

6. Connect the RJ11 connector end of the BTS to the BTS port (Figure 1-4, Item 9) on the inverter.
7. Connect the other end of the BTS to the negative terminal of the last battery string (place hardware per Figure 2-4).

Final Checks

- Connect the two Anderson connectors.
- Ensure the DC wire connections (on the battery terminals, fuse lugs/DC circuit breaker, and disconnect) are flush on the surface of the DC terminals, and the hardware (lock washer and nut) used to hold these connections in place are stacked correctly (see Figure 2-4).
- Verify all DC connections are torqued from 10 to 12 ft-lbs.
- Once the DC connections are completely wired and tested, coat the terminals with an approved anti-oxidizing spray.
- If batteries are in an enclosure, check the hold down brackets and all connections. Close and secure the battery enclosure.

2.4 Connecting to the 3-Port Terminal Block

The MMA inverter/charger provides a 3-port terminal block on the right side of the unit (Figure 2-5) that can be used to connect an auxiliary DC load—(AUX), an ignition control switch—(ICS), and a ground control switch—(GCS). See also Figure 2-6.

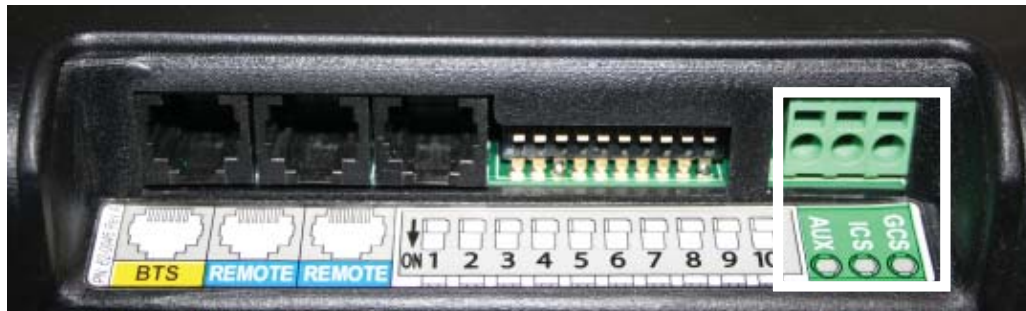

Figure 2-5, MMA1212's 3-Port Terminal Block

Installation

Aux DC Output (AUX)

The Aux Output port provides auxiliary DC power from the battery for small loads not exceeding 20 amps (e.g., an interior lamp, backup camera, etc.). Whenever +12V is applied to the ignition (ICS) input, an internal relay closes and provides battery voltage (up to 20 amps) on the auxiliary (AUX) DC output.



Info: The MMA inverter/charger must be connected to the battery for the aux DC output to be available.

Ignition Control Switch (ICS)

With an ignition switch (a +12 VDC signal) wired to this port, the inverter automatically turns on (in turn disabling the inverter's ON/OFF switch and the remote's ON/OFF button—if connected). Refer to the Switch 2 section on pages 25-26 for information on setting up an ignition control switch for your system, and for other conditions and considerations that affect this feature.

Ground Control Switch (GCS)

With a ground switch wired to this port, you can automatically turn on the MMA1012 inverter/charger (in turn disabling the inverter's ON/OFF switch and the remote's ON/OFF button—if connected). Refer to the Switch 3 section on page 26 for information on setting up a ground control switch for your system, and for other conditions and considerations that affect this feature.

2.5 Remotes and Connections

2.5.1 Remotes and Remote Settings

Several remotes are available that let you monitor the inverter/charger and enable you to switch the inverter on/off from a convenient location.

Note: *The remotes easily connect to either of the inverter's Remote ports, however only **one** remote control (MM-R, MM-RC, ME-RC, ME-MR, or ME-ARC) can be connected to the inverter at any time. The MM-C monitor is the only remote that can be connected to the inverter with one of the remote controls.*

MM-R – Provides three LED indicators (INVERT, AC IN, FAULT) for inverter status and a remote ON/OFF power switch; has 25' cable.

MM-C (monitor only) – Provides three LED indicators (BULK, ABSORB, FLOAT) for battery and charger status—has 25' cable.

MM-RC – Provides six LED indicators for inverter/battery charger statuses, and includes a remote ON/OFF power switch; has 25' cable.

ME-RC50/ME-ARC50 – Full feature remotes with backlit LCD display and LED indicators for inverter and charger status.

Note: *The ME-RC50 and ME-ARC50 are used for many inverter models and have features that are not functional with the MMA1212.*

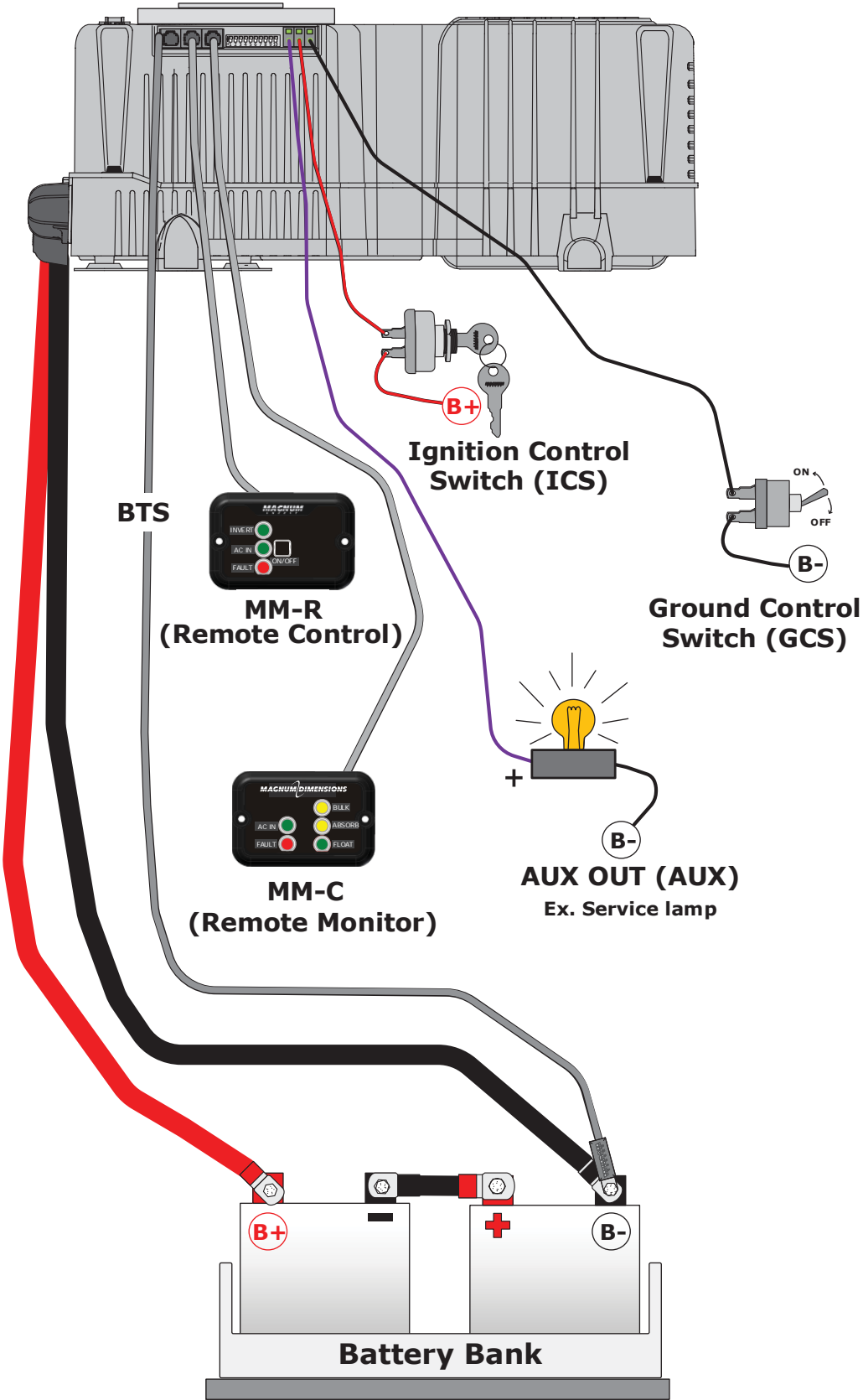

Figure 2-6, MMA1212 Accessory Connections

2.6 Inverter Warning Label

The warning label (Figure 2-7) is provided to inform all personnel that an inverter is installed in your electrical system. Affix this label in a clearly visible location at the electrical panel that is being powered by the inverter. This is necessary because it might be falsely assumed that the panel is no longer “hot” after AC power has been shut off—when in fact power may actually still be available due to the inverter automatically powering the panel.

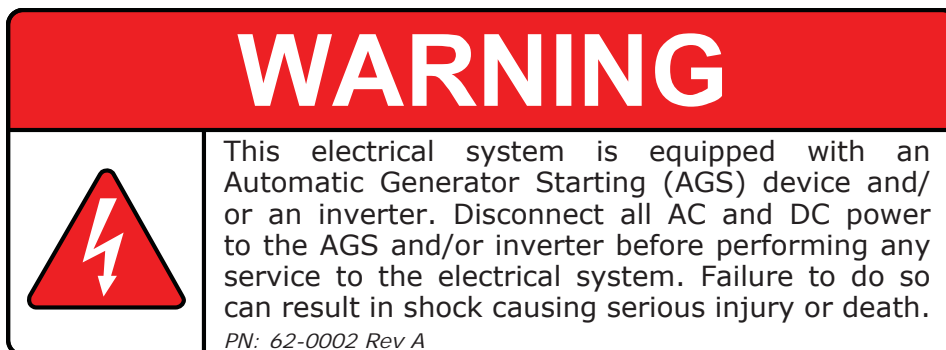

Figure 2-7, Warning Label

2.7 GFCI Breakers

When installing a MMA1212 inverter in an ambulance’s wiring system, a ground fault circuit interruption breaker (GFCI) may be installed to protect some branch circuits powered by the inverter. In compliance with UL standards, Sensata has tested the following GFCI’s and has found that they function properly when connected to the inverter’s AC output (there are others on the market that will work as well): *Shock Sentry™ #VGF15W*, *Leviton Smart Lock #7899*, or *Hubbel #GF520EMBKA*.



WARNING: Risk of electric shock. Use only ground-fault circuit interrupters (receptacles or circuit breakers) that are compatible with your MMA inverter. Some types may fail to operate properly when connected to this inverter equipment.



WARNING: Ground Fault Circuit Interrupters (GFCIs) shall be installed in the vehicle’s wiring system to protect all branch circuits.

2.7.1 AC Neutral to Safety Ground Bonding

Electrical safety standards for wiring mobile installations in the U.S.A. require the neutral and safety ground to be connected at the AC source; whether it is the utility feed in the RV park/marina, an inverter, or a generator. This is to establish a specification that maximizes the possibility that a circuit breaker will activate if a hot wire-to-ground fault occurs. These standards also require that the AC neutral be connected to safety ground (a “bond”) in one, and only one, place at any time. The single bond is established in order to make the electrical panel’s neutral line safe, by connecting it to ground. Without this bond, the neutral can have up to 60 VAC with respect to ground. However, if more than one bond is established, currents can circulate between neutral and ground and cause “ground-loop” currents. Ground-loops can trip GFCIs, cause an electric shock hazard, or result in other annoying side effects.

In applications using an inverter as one of your AC sources along with another AC source (i.e., utility power or generator), there is the potential of having multiple connections (bonds) between neutral and ground. Therefore, you must ensure that the inverter does not also connect the neutral-to-ground while the other AC source is actively powering the inverter loads. This can be prevented if your inverter is equipped with automatic neutral-to-ground switching.



WARNING: In most electrical systems, the neutral-to-ground bond is located in the main utility service entrance panel. Remove any bond downstream from the inverter to prevent multiple bonds. If there is an inverter sub-panel—separate from a main electrical panel—it should have a removable wire that allows the neutral bus to be unbonded from the ground busbar.



CAUTION: The AC input neutral terminal is electrically isolated from the AC output neutral terminal while inverting (helps prevent ground-loops). The input and output neutrals must not be connected together at any time, or damage to the inverter may occur.

The MMA inverter has automatic neutral-to-ground switching to specifically work in multiple source or mobile (i.e., truck/RV/boat) applications. The MMA uses an internal relay that automatically connects the AC neutral output terminal to the vehicle’s ground while inverting (Inverter mode) to provide the neutral-to-ground bond. However, when an external AC source (i.e., utility or a generator) is connected, another neutral-to-ground connection is introduced in the system. When the inverter is connected to this external AC source and goes into Standby mode, the internal relay automatically opens the neutral-to-ground connection. This design keeps two neutral-to-ground connections from occurring at the same time, thereby preventing an electrical shock hazard between the vehicle’s neutral and the external AC source’s neutral.

2.8 Functional Test

After all electrical connections to the inverter, batteries, AC source, and loads (using a sub-panel) have been completed, follow these steps to test the installation and the inverter's operation.

1. Check the battery voltage and polarity before connecting the batteries to the inverter. Use a multimeter to verify 10 to 15 VDC at the batteries' positive and negative terminals.
2. Apply battery power to the inverter by switching the DC disconnect on (or close the DC circuit-breaker). The inverter remains off, but the LED status indicators go through a start-up test (see Section 4.1.1) to indicate that DC power has been connected and is ready to be turned on.
3. Prior to turning on the inverter, ensure all connected loads (e.g., medical devices) are switched off or disconnected from the AC outlets.
4. a) If a remote switch is connected, press the remote's ON/OFF switch to turn on the inverter.
b) If there is no remote switch connected, lightly press and release the inverter's ON/OFF power switch—located on the top of the inverter—to turn the inverter on.
Verify the inverter's INV LED status indicator is solid—indicating the inverter is providing AC power.
5. Check the output voltage of the inverter by connecting a true RMS multimeter to the outlets powered by the inverter. Verify the voltage is 120 VAC +/- 5 VAC.
6. Turn on or connect a load and verify it comes on. Continue to keep the load connected and turned on.
7. Press the remote's ON/OFF switch to turn the inverter off. If no remote switch is connected, press and release the inverter's ON/OFF power switch to turn the inverter off. The INV LED status indicator and the connected load should go off.
8. Apply AC power to the inverter's AC input. After the AC input power is qualified (approximately 15 seconds), the incoming AC power transfers through the inverter to the AC output and the connected load is powered. Verify one of the inverter's CHG LEDs illuminates and the connected load comes on.
9. Even though the connected load is on, the inverter is currently disabled/off. Press the remote's ON/OFF switch (or press and release the ON/OFF power switch on the inverter) to enable/turn-on the inverter.
10. Disconnect the incoming AC power to the inverter. Verify the connected load remains on—but now is powered by the inverter.

If the inverter passes all the steps, the inverter is ready for use.

If the inverter fails any steps, refer to the Troubleshooting section.

3.0 Setup

When the MMA inverter/charger is not connected to a remote, the internal DIP switches (Figure 1-4, Item 11) are used to determine its operation.



Info: When the MMA is connected and networked with a remote, the remote can be used to set up and/or control the MMA's operation. Refer to your remote owner's manual for setup information.

3.1 Adjusting DIP Switch Settings

The DIP (Dual In-line Package) switch includes 10 individual slide switches that can be set to the UP or DOWN position (Figure 3-1). As a standalone inverter (i.e., not connected to a remote control), the arrangement of the 10 switches determines the MMA's operating parameters. The default setting (all DIP switches UP) is adequate for most installations, however you have the option to change some of the operating parameters. This section shows how to set the DIP switch and provides information on each switch setting's function. Use the DIP switch adjustments described below to configure your MMA1212 inverter/charger.



CAUTION: The MMA does not warn against or disallow incorrect DIP switch settings. Ensure the settings used to charge the batteries—the *Absorption Done Time* and *Battery Type* selections—are carefully checked against your battery's specifications. Incorrect settings may damage the battery or shorten battery life.



Info: When changing any DIP switch setting, ensure each switch is fully in the UP or DOWN position as needed. The switch settings can be changed at any time, even while the unit is operating. DIP switch changes become effective when initiated, and do not require power to the MMA to be cycled on and off.

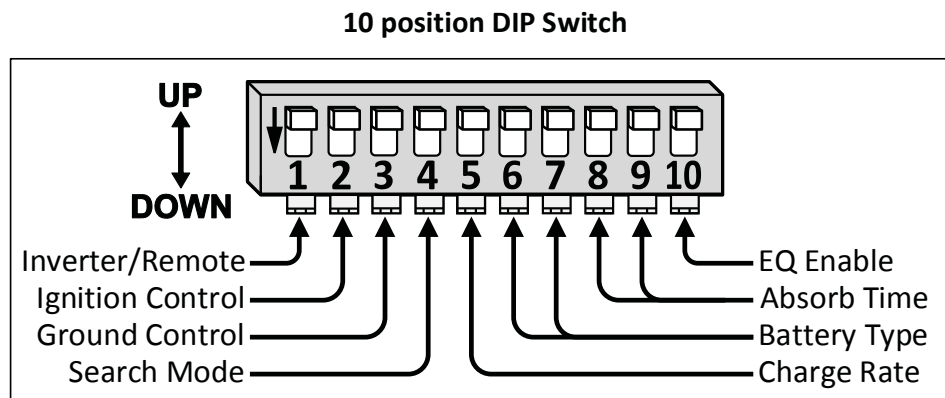

Figure 3-1, DIP Switch Summary

Setup

Switch 1: Use Inverter or Remote Settings

When a remote control is connected to the MMA, DIP Switch 1 determines whether the MMA uses the inverter's (DIP) settings or the connected remote's settings to set up and/or control the MMA's operation.

If DIP Switch 1 is UP, the inverter runs on the DIP switch settings (See Table 4-3). If DIP Switch 1 is UP and a remote is connected, the inverter continues running on the DIP switch settings and ignores the remote settings—except for any settings not determined by any of the DIP switches.

When DIP Switch 1 is DOWN and a remote control is connected to the MMA, the settings from the remote are used instead of the DIP switch settings.

Note: Inverter continues to use remote settings even if the remote is then disconnected—until power to the inverter is cycled, or DIP Switch 1 is set UP.



Info: If DIP Switch 1 is DOWN and a remote control is not connected or detected, the DIP switch settings will be used instead.



Info: If a remote is connected and DIP Switch 1 is in the DOWN position, the settings from the remote control override all DIP switch settings except for Switches 2, 3, and 10—which are still active with a remote connected.

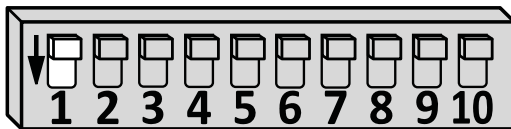

Use DIP Switch Settings
(UP)

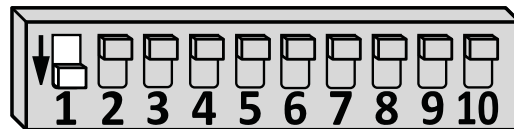

Use Remote Settings
(DOWN)

Switch 2: Ignition Control Switch (ICS)

In certain installations it may be desirable to automatically turn on loads connected to the inverter (e.g., backup camera) when a +12VDC signal is supplied to the ICS terminal (Figure 1-4, Item 12)—such as when turning on an ignition switch. The position of the Ignition Control Switch (DIP Switch 2) determines if a +12VDC signal connected to the ICS terminal causes the MMA inverter to automatically turn on—and the ON/OFF switch on the inverter (and remote control, if connected) to be disabled.

If DIP Switch 2 is UP (ignition control disabled), a +12VDC signal connected to the ICS terminal is ignored and has no effect on turning the inverter on/off, and the inverter's ON/OFF switch (and remote control, if connected) can be used to turn the inverter on and off.

If this DIP switch is DOWN (ignition control enabled), the inverter is forced on and cannot be turned off when a +12VDC signal is connected to the ICS terminal; and is forced off and cannot be turned on when the +12VDC signal is removed.



Info: If the inverter is on, supplying a +12VDC signal to the ICS terminal causes the 20A aux DC output voltage to be available on its output terminal—even if the ignition control switch is disabled (i.e., DIP Switch 2 is UP).



Info: If DIP Switches 2 & 3 are both enabled (DOWN), then both signals (+12VDC and ground) must be connected to their appropriate terminals for the inverter to be forced on; and when one or both signals are removed, the inverter is forced off.

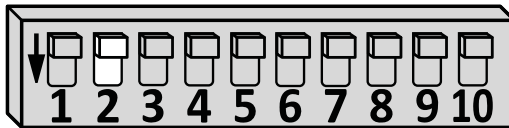

Ignition Control Disabled
(UP)

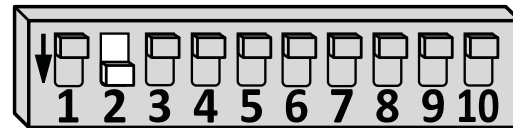

Ignition Control Enabled
(DOWN)

Switch 3: Ground Control Switch (GCS)

The position of the Ground Control Switch (DIP Switch 3) determines if a ground connection supplied to the GCS terminal (Figure 1-4, Item 12) causes the MMA inverter to automatically come on—and the ON/OFF switch on the inverter (and remote control, if connected) to be disabled.

If DIP Switch 3 is UP (ground control disabled), a ground connection to the GCS terminal is ignored and has no effect on turning the inverter on or off, and the switch on the inverter (and remote control, if connected) can be used to turn the inverter on and off.

If DIP Switch 3 is DOWN (ground control enabled), a ground connection to the GCS terminal forces the inverter to come on and disables the switch on the inverter (and remote control, if connected). This means the inverter cannot be turned off when ground is connected to the GCS terminal; and when ground is removed, the inverter is forced off and cannot be turned on.



Info: If DIP Switches 2 & 3 are both enabled (DOWN), then both signals (+12VDC and ground) must be connected to their appropriate terminals for the inverter to be forced on; and when one or both signals are removed, the inverter is forced off.

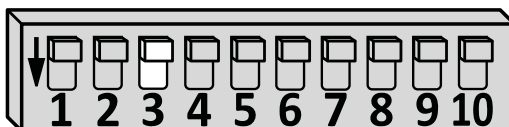

Ground Control Disabled
(UP)

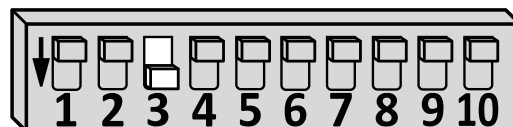

Ground Control Enabled
(DOWN)

Setup

Switch 4: Search Mode

The position of DIP Switch 4 allows you to enable the power-saving Search mode circuitry. Normally, the inverter is providing full AC voltage to the loads (DIP Switch 4 is UP). When Switch 4 is set DOWN, the Search mode feature is activated. When Search mode is active, the inverter sends out pulses—consuming very little energy from the battery—until the power level of the loads on the inverter are above 5 watts, causing the inverter to “wake up” and start providing full AC output.

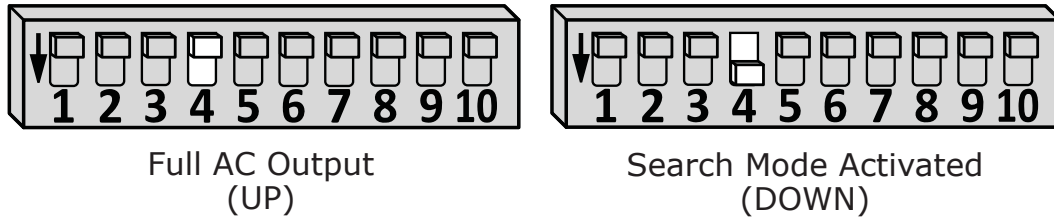

Switch 5: Charge Rate

The DIP Switch 5 setting determines the maximum current allowed to charge the batteries during Bulk, Absorption, Float, and Equalize charging. The two selections are provided as a percentage of the inverter/charger’s maximum charging capability. Refer to the label on the back side of the inverter (or Table 6-1) to determine the inverter’s 100% (or maximum) charge rate.

With DIP Switch 5 set UP (100% Charge Rate), the charger can deliver 100% of the available charging capability of the inverter. With DIP Switch 5 set DOWN (30% Charge Rate), the charge rate will be limited to 30% of the maximum charging capability of the inverter. This 30% setting is provided to help prevent battery overheating caused by charging at too high a charge rate.

Example: The maximum charge rate of your inverter/charger is 50 amps. When the DIP switch is set DOWN, the charge rate is limited to 15 amps (15 amps = 30% of 50 amps).

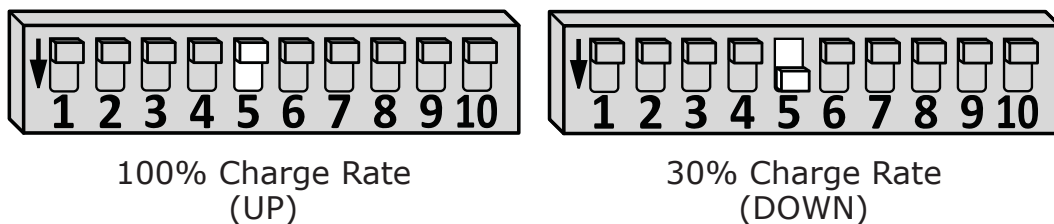

Switches 6 & 7 Battery Type

Switches 6 & 7 are used to select the battery type—which determines the battery charge profile and ensures the batteries are receiving the proper charge voltage. Select the battery type that matches your system’s battery bank chemistry, or refer to Table 3-1 to determine the specific charge voltage to use based on the battery type selected.

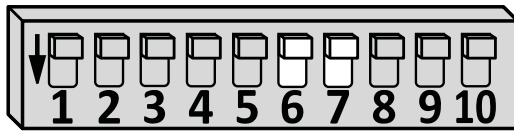

Flooded

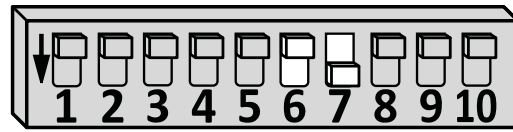

AGM 1

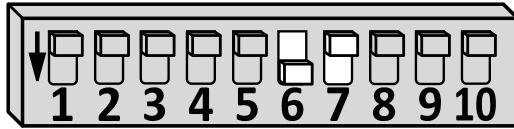

GEL

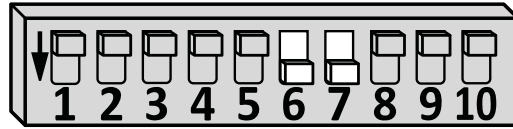

AGM 2



Info: Voltages shown in Table 3-1 are based on the Battery Temperature Sensor (BTS) being disconnected, or at a temperature of 77°F (25°C). If the BTS is connected, the charge voltage changes based on the temperature around the BTS—to ensure the batteries receive the correct charge voltage even if they become cold or hot (see Section 1.5.2).

Table 3-1, Battery Type to Charge Voltages

Battery Type	Absorption Voltage	Float Voltage	Equalization Voltage	Equalization Time
Flooded	14.6 VDC	13.4 VDC	15.5 VDC	2.0 Hours
GEL	14.1 VDC	13.6 VDC	Not Allowed	Not Applicable
AGM 1 ¹	14.3 VDC	13.1 VDC	15.5 VDC	2.0 Hours
AGM 2 ²	14.5 VDC	13.5 VDC	Not Allowed	Not Applicable

Note¹: Specs for Concord (Lifeline Series) AGM batteries.

Note²: Specs for East Penn, Deka, Discover & Trojan AGM batteries.

Switches 8 & 9: Absorb Time

DIP Switches 8 & 9 determine the absorption charge time of the MMA inverter/charger. Four (4) time periods are provided to determine how long the charger is in the Absorb Charge stage—holding the batteries at the *Absorb Voltage* setting.

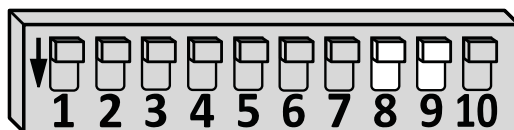

60 Minutes

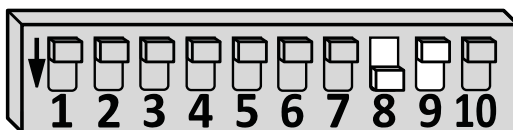

120 Minutes

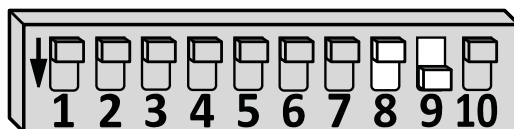

90 Minutes

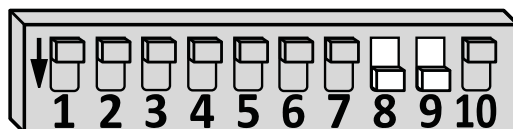

150 Minutes

Setup

Switch 10: EQ Enable

The position of DIP Switch 10 allows an Equalize (EQ) charge to be started or stopped by the inverter. An EQ charge can be started by setting DIP switch DOWN or by using a connected remote. When an EQ charge starts, the position of DIP Switch 1 determines if the EQ charge settings (EQ voltage and time period) are dictated by the inverter settings or by the connected remote. Once the EQ charge has started, it will automatically stop once the EQ charge is complete, or it can be manually be stopped by setting DIP Switch 10 to UP, or by disabling Equalize from the remote—if connected.



Info: Once DIP Switch 10 has been set DOWN, it must be cycled (i.e., set UP then DOWN) to start another EQ charge using DIP Switch 10.



Info: EQ charge is only permitted if the Battery Type selection allows, and the charger is in Float charge or Full charge mode.



Info: Charge LED's (BULK, ABSORB, and FLOAT) each come on in sequence to indicate the charger is equalizing.

DIP Switch 1 UP (use inverter settings): When DIP Switch 1 is UP and an EQ charge is started, the charger uses the inverter's battery type selection to determine the EQ voltage and time period. To EQ charge, ensure the charger is in the Float charge or Full charge stage, and then set DIP Switch 10 to DOWN. The EQ charge begins (if *Battery Type* selection allows—see Table 3-1) and continues for 2 hours, and then automatically stops and returns to float charging.



Info: If DIP Switch 1 is UP and a remote is connected, the remote can be used to start an EQ charge, but the inverter's charge settings will continue to be used.



Info: When Equalize charging, the maximum current allowed to charge the batteries is set by the DIP Switch 5 (Charge Rate) setting.

DIP Switch 1 DOWN (use remote control settings): When DIP Switch 1 is DOWN and a remote control with the Equalize feature is connected, the Equalize charge settings from the remote are used. To Equalize charge, ensure the charger is in the Float Charge or Full Charge stage, then start the EQ charge—either from the remote or by setting DIP Switch 10 to DOWN. The Equalize charge begins (if the remote's *Battery Type* selection allows) and uses the remote control settings to determine the Equalize voltage and time period.

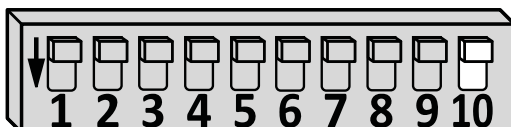

Disable EQ Charge (UP)

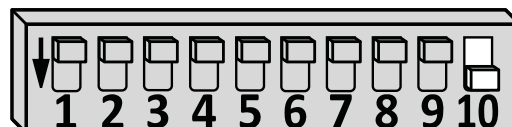

Start EQ Charge (DOWN)

4.0 Operation

This section discusses the MMA inverter/charger's ON/OFF switch and LED indicators, explains how the MMA operates, provides information on the various remotes (and other accessories) that can be connected to the unit, and lists the inverter's/remote's default settings.

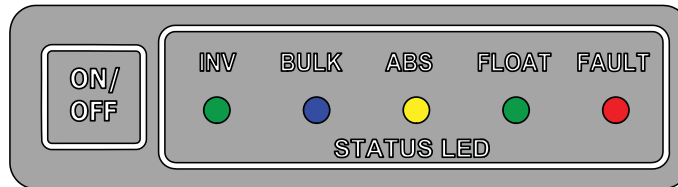

Figure 4-1, Top Panel Power Switch and LED Indicators

4.1 MMA Top Panel Features

The top panel (Figure 4-1) is used to turn the MMA on/off and to monitor its operational status. It is comprised of the following:

ON/OFF Pushbutton – The momentary pushbutton switch on the top of the inverter is used to turn the inverter on and off.

When the inverter is connected to the batteries—or when its automatic protection circuit has turned the inverter off—the ON/OFF pushbutton switch must be pressed to start the unit. Once the inverter has been turned on, pressing the ON/OFF switch alternately turns the unit off and on.



Info: The power ON/OFF pushbutton is a small momentary type switch which operates by lightly pressing and releasing.



WARNING: When any external AC power is passing through the inverter and is present on the output, pressing the ON/OFF switch will not remove this AC power on the inverter's output.

Inverter Status LED Indicator – The inverter's status indicator (INV) is a green LED that provides information on the operational mode of the inverter. Watch the INV LED status indicator for at least 10 seconds to determine (or to verify) the inverter's operational condition—using the information below.

- *INV LED off* – The inverter is off. There is no AC power from the inverter, shore, or generator at the inverter's output terminals.
- *INV LED on (solid)* – The inverter is on and using energy from the battery. The inverter is providing full power to any loads connected to the inverter.

Operation

- *INV LED blinks once per second* – The inverter is connected to an external AC source (utility or generator power) and is in Standby mode. The inverter is ready to turn on and supply power to the loads if the external AC source is disconnected.
- *INV LED blinks twice per second (double blink)* – The inverter is in Search mode and is ready to supply AC power to the loads connected to the inverter—when a load greater than 5 watts is connected.

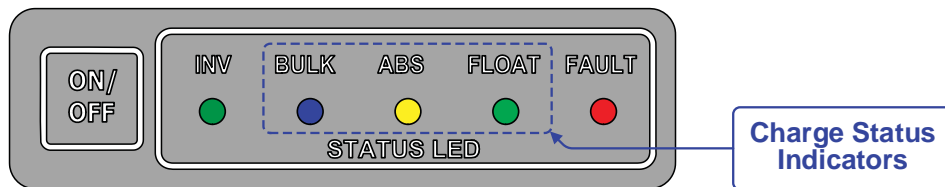

Figure 4-2, Charge Status Indicators

Charge Status LED Indicators – The at-a-glance charge LED’s (Figure 4-2) provide information on the inverter’s status while in Charge mode. Refer to Table 4-1 to identify the charger operation using these LED’s (BULK – blue; ABSORB – yellow; FLOAT – green).



Info: When one of the charge indicators is on, the external AC power (utility power or generator) that is connected to the inverter’s input is also passing through the inverter to power the AC loads on the inverter’s output.



Info: Whenever AC power (utility or generator) is present at the inverter’s AC input and is within the AC input limits (voltage and frequency), it connects and passes through the inverter—whether the inverter is on or off.

Table 4-1, Charge Status LED Indicators

BULK (blue)	ABSORB (yellow)	FLOAT (green)	Description
OFF	OFF	OFF	Charging Off – No external AC source is connected, or there is a charger fault.
ON	OFF	OFF	Bulk Charge Stage – Charger is delivering maximum current to the batteries. Charger remains in bulk charge until the absorb target voltage ¹ is achieved.
Blink (x1 sec) ³	OFF	OFF	Charger Back-off (in Bulk Charge mode) – Charger is in Charger Back-off ² , limiting charging current to the battery.

BULK (blue)	ABSORB (yellow)	FLOAT (green)	Description
OFF	ON	OFF	Absorb Charge Stage – Charger is in Constant Voltage stage and begins after the bulk voltage is reached. The DC charging current will taper down in order to maintain the battery at the absorb target voltage ¹ .
OFF	Blink (x1 sec) ³	OFF	Charger Back-off (in Absorb Charge mode) – Charger is in Charger Back-off ² , limiting charging current to the battery.
OFF	OFF	ON	Float Charge Stage (in Float Charge mode) – Float Charge occurs at end of absorb charging time—reduces the charge voltage to maintain the batteries at the float target voltage ¹ .
OFF	OFF	Blink (x1 sec) ³	Charger Back-off – Charger is in Float Charge mode and in Charger Back-off ² , limiting charging current to the battery.
OFF	OFF	Blink (x2 sec) ³	Full Charge Stage – Full Charge stage turns the charger off and monitors battery voltage to determine when to continue charging. After four hours in Float Charge mode, charger goes to Full Charge mode. If battery voltage drops to a low level (~12.9 VDC), the charger automatically initiates another float charge.
1st ON	2nd ON	3rd ON	Equalize Charge Stage – Charger is in the Equalize Charge stage, regulating the current to maintain the battery at the equalize target voltage ¹ . Note: Each charge status LED indicator is on for two seconds in sequence.

Note¹: Target Voltage – The temperature compensated voltage regulation set-point. The battery will be regulated to the voltage setting determined by the active charge stage (i.e., Absorb, Float, or Equalize) and the Battery Type DIP switch setting; and includes any voltage increase or decrease based on the temperature around the BTS.

Note²: Charger Back-off occurs if: 1) The FET or internal temperature is very hot (the charger reduces the charge rate to maintain temperature); or, 2) The AC input voltage has fallen below 85 VAC (the charger reduces the charge rate to help stabilize the incoming AC voltage).

Note³: There is a two-second pause between each blink sequence. Example: Blink (x2 sec) means the LED blinks twice within a second and then is off for 2 seconds—this sequence continues while in this status.

Operation

Fault LED Indicator – Under normal operating conditions, the FAULT LED (red) indicator will be off. If there is a fault condition, this indicator illuminates to indicate that a fault condition has shut down the inverter. When the FAULT LED comes on, count the number of times it blinks (before turning off for three seconds) to determine the particular reason for the shutdown. Once you have identified and cleared the fault, the inverter can be turned on. To help clear the fault condition, refer to the Troubleshooting section.

- *Blinks x1, then off for 2 secs* – **Low Battery Voltage**; the battery voltage level has dropped below 10.0 VDC (*LBCO* default). Your batteries need to be charged. This fault condition automatically clears when the battery voltage exceeds 12.5 VDC.
- *Blinks x2, then off for 2 secs* – **High Battery Voltage**; the battery voltage is above 16.9 VDC. Reduce or turn off the external charging source to bring the battery voltage down.
- *Blinks x3, then off for 2 secs* – **Over-temperature Condition**; the internal inverter temperature is above acceptable limits. This may be caused by loads too great for the inverter to operate continuously, or by lack of ventilation to the inverter. When the unit has cooled, it automatically resets and resumes operation.
- *Blinks x4, then off for 2 secs* – **AC Overload**; the inverter has turned off because the connected loads are larger than the inverter's output capacity, or there is a short on the output wiring. Restart the inverter once the AC loads are reduced or the wiring short has been removed. To restart the inverter, momentarily press the ON/OFF button on the inverter or remote.
- *Blinks x5, then off for 2 secs* – **Internal Fault**; the inverter has turned off because it has detected an internal problem. To clear this fault, the inverter needs to be reset: 1) Press and hold the inverter's ON/OFF switch for 10 seconds (inverter goes thru power-up test – see Section 4.1.1) or, 2) Disconnect all DC power to the inverter for at least 10 seconds, and then reconnect. After resetting the inverter, momentarily press the inverter's ON/OFF switch and verify the fault cleared. If the internal fault remains, the inverter requires service at an authorized repair facility.
- *Blinks x6, then off for 2 secs* – **High AC Volts**; this fault causes the AC input to be disabled because a very high AC voltage (>145 VAC) has been detected on the AC input. To clear this fault, remove all AC power from the inverter's AC input for at least 15 minutes. Ensure only 120 VAC power is connected to the inverter's AC input.

4.1.1 Power-up LED Test

When the inverter is first connected to the batteries, the inverter and remote go through a power-up test. This test verifies the inverter's LED's by requiring all LED's to come on in sequence from the first (INV) to the last (FAULT), and after all LED's are on for 2 seconds they all turn off.

4.2 Operating Modes

The MMA1212 inverter/charger has two normal operating routines. Inverter mode, which powers the loads using the batteries; and Standby mode, which transfers the incoming AC power (i.e., shorepower or a generator) to power the loads and to recharge the batteries. This inverter also includes an extensive protection circuitry that shuts down the inverter under certain fault conditions.

4.2.1 Inverter Mode

When the MMA is first powered up, it defaults to the OFF mode. The inverter's momentary ON/OFF power switch must be lightly pressed to turn the inverter on. Subsequently pressing this switch alternately turns the inverter off and on.

- **Inverter OFF** – When the inverter is off, no power is used from the batteries to power the AC loads and the status LED will be off. If AC power from an external source (shorepower or generator) is connected and qualified on the inverter's AC input, this AC input power will pass through the inverter to power the AC loads. However, if this AC power is lost, the AC loads will no longer be powered because the inverter is off.

When the inverter is turned on, it operates either by "Searching" or "Inverting", depending on the connected AC loads.

- **Searching** – When the inverter is first turned on, the automatic Search feature is disabled. This feature is provided to conserve battery power when AC power is not required. In this mode, the inverter pulses the AC output looking for an AC load (i.e., electrical appliance). Whenever an AC load (greater than 5 watts) is turned on, the inverter recognizes the need for power and automatically starts inverting. When there is no load (or less than 5 watts) detected, the inverter automatically goes back into Search mode to minimize energy consumption from the battery bank. When the inverter is "searching", the inverter's green LED flashes twice.



Info: The factory default value for the Search feature is 5 watts. It can be turned off or adjusted from 5 to 50 watts using the ME-MR, ME-RC, or ME-ARC remote display.

- **Inverting** – When a load greater than 5 watts is connected to the inverter output, the MMA1212 "inverts" the DC power from the battery and supplies 120 VAC power to your sub-panel. The inverter's green LED is on solid to indicate it is inverting. The amount of time the inverter can be inverting and providing power is directly related to the amount of AC loads that are connected, and the capacity of the battery bank.

4.2.2 Standby Mode

The MMA1212 features an automatic transfer relay and an internal battery charger when operating in Standby mode. Standby mode begins whenever AC power (shorepower or generator) is connected to the inverter's AC input. Once the AC voltage and frequency of the incoming AC power is within the AC input limits, an automatic AC transfer relay is activated. This transfer relay passes the incoming AC power through the inverter to power the AC loads on the inverter's output. This incoming power is also used to activate a powerful internal battery charger to keep the battery bank charged in case of a power failure.

Battery Charging – The MMA1212 model is equipped with an active Power Factor Corrected (PFC) multi-stage battery charger. The PFC feature is used to control the amount of power used to charge the batteries in order to obtain a power factor as close as possible to 1 (or unity). This causes the battery charger to look like a resistor to the line (forces the charge current waveshape to mirror the voltage waveshape). This feature maximizes the real power available from the AC power source (shorepower or generator), which translates into less power wasted and a greater charging capability than most chargers available today.

When an AC power source is connected to the MMA, the inverter monitors the AC input for acceptable voltage. Once the inverter has accepted the AC input, the AC transfer relay will close and charging will begin. Once charging, the DC voltage is monitored to determine the charging stage. If the DC voltage is low (≤ 12.9 VDC), the charger begins bulk charging. If the DC voltage is high (> 12.9 VDC), the charger skips the initial bulk/absorb charging stages and goes directly to float charging.

The multi-stage charger can use up to five different charging stages to help monitor and keep the batteries healthy. The five stages include an automatic 4-stage charging process (Bulk, Absorb, Float, and Full Charge), and a manual Equalization (EQ) charge stage. The automatic 4-stage charge process provides complete recharging and monitoring of the batteries without damage due to overcharging (see Figure 4-3). The Equalization stage (requires a ME-MR, ME-RC, or ME-ARC remote control) is used to stir up stratified electrolyte and reverse any battery plate sulfation that might have occurred.

While charging, the unit may go into **Charger Back-off** protection, which automatically reduces charge current to the batteries, because:

1. The internal temperature is too hot – the charger automatically reduces the charge rate to maintain temperature.
2. The AC input voltage falls < 85 VAC – the charger reduces the charge current to zero to help stabilize the incoming AC voltage.

The automatic 4-stage charging process includes:

Bulk Charging: This is the initial stage of charging. While bulk charging, the charger supplies the battery with constant current. The charger remains in bulk charge until the absorption charge voltage is achieved (14.6 VDC)* (per *Battery Type* selection**).

Absorb Charging: This is the second charging stage and begins after the bulk voltage has been reached. Absorb charging provides the batteries with a constant voltage and reduces the DC charging current in order to maintain the absorb voltage setting. The absorb charging time is 60 minutes (per *Battery AmpHrs* selection**).

Float Charging: The third charging stage occurs at the end of the absorb charging time. While float charging (also known as a maintenance charge), the batteries are kept fully charged and ready if needed by the inverter. This stage reduces battery gassing, minimizes watering requirements (flooded battery), and ensures the batteries are maintained at optimum capacity. In this stage, the charge voltage is reduced to the float charge voltage (13.4 VDC)* (per *Battery Type* selection**)—maintain batteries indefinitely.

Full Charge (Battery Saver™ mode): The fourth stage occurs after four hours in the float charging. The Full charge stage maintains the batteries without overcharging, preventing excessive loss of water in flooded batteries or drying out of GEL/AGM batteries. In this stage, the charger is turned off and begins monitoring the battery voltage. If the battery voltage drops low (≤ 12.7 VDC), the charger will automatically initiate another four hours in float charge.

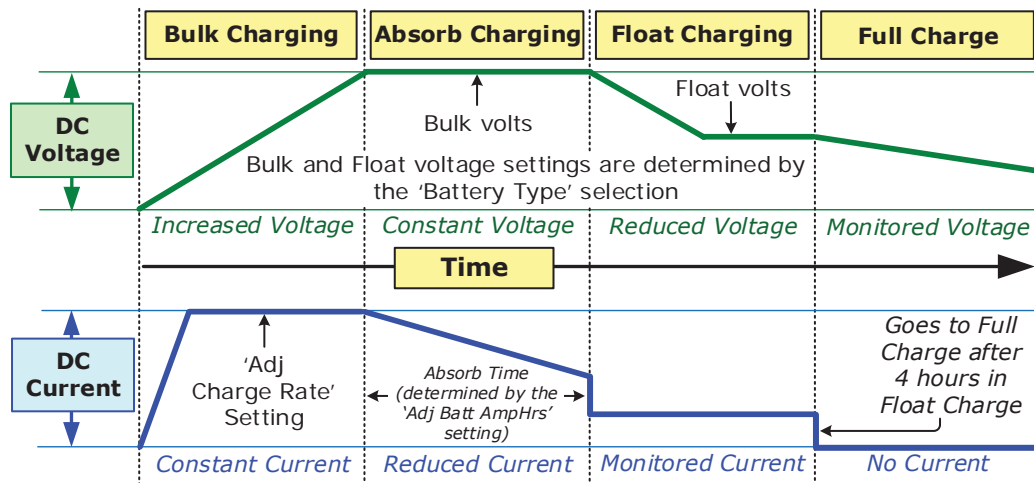

Figure 4-3, Automatic 4-Stage Charging Graph

* Voltage settings based on the Battery Temperature Sensor (BTS) being disconnected, or at a temperature of 77°F (25°C). If BTS is installed, these voltage settings increase if the temperature around the BTS is <77°F (25°C), and decrease if the temperature around the BTS is >77°F (25°C).

** The MMA uses changeable settings (see Table 4-3) that are adequate for most installations. However, if some of your operating parameters need to be changed, the ME-MR, ME-RC, or ME-ARC remote control can be purchased to allow change to those settings.

Operation

Transfer time – While in Standby mode, the AC input is continually monitored. Whenever AC power falls below the VAC dropout voltage (80 VAC, default setting), the inverter automatically transfers back to Inverter mode with minimum interruption to your appliances—as long as the inverter is turned on. The transfer from Standby mode to Inverter mode averages approximately 16 milliseconds. While the MMA1212 is not designed as a computer UPS system, this transfer time is usually fast enough to hold them up. However, the *VAC Dropout* setting has an effect on the ability of the loads to transfer without resetting. The lower this setting, the longer the effective transfer will be and therefore, the higher the probability for the output loads to reset. This occurs because the incoming AC voltage is allowed to fall to a level that is so low that when the transfer does occur, the voltage on the inverter’s output has already fallen to a low enough level to reset the loads.

The disadvantage of a higher *VAC Dropout* setting is that smaller generators (or large generators with an unstable output) may nuisance transfer. This commonly happens when powering loads that are larger than the generator can handle—causing the generator’s output voltage to constantly fall below the inverter’s input VAC dropout threshold.



Info: You must use the ME-MR, ME-RC, or ME-ARC remote to adjust the VAC dropout setting—which in turn determines the VAC dropout threshold.



Info: When switching from Inverter mode to Standby mode, the inverter waits approximately 15 seconds to ensure the AC source is stable before transferring.

4.3 Protection Circuitry Operation

The inverter is protected against fault conditions, and in normal usage it will be rare to see any. If a condition occurs that is outside the inverter’s normal operating parameters, then it will shut down and attempt to protect itself, the battery bank, and your AC loads. Refer also to the Troubleshooting section to diagnose and clear any of the fault conditions below.

- **Low Battery** – The inverter shuts down whenever the battery voltage falls to the Low Battery Cut Out (LBCO) level for over one minute to protect the batteries from being over-discharged. Once the inverter has reached the LBCO level and turned off, it will automatically restart after one of the following conditions:
 1. AC power is applied and the inverter begins operating as a battery charger.
 2. Battery voltage rises to the Low Battery Cut In (**LBCI**) level.

The INV LED turns off when a low battery fault condition occurs. Refer to Table 4-2 to determine the LBCO and LBCI levels for your particular inverter model.

- **High Battery** – In the event the battery voltage approaches the High Battery Cut Out (**HBCO**) level, the inverter will automatically shut down to prevent the inverter from supplying unregulated AC output voltage. The INV LED turns off when a high battery fault condition occurs. The inverter will automatically restart when the battery falls to the High Battery Cut In (**HBCI**) level. Refer to Table 4-2 to determine the HBCO and HBCI levels for your particular inverter model.



Info: High battery voltage may be caused by excessive or unregulated voltage from solar panels or other external charging sources.

- **Overload** – During Inverter and Standby operation modes, the inverter monitors the DC and AC current levels. In the event of a short-circuit or an overload condition for more than a few seconds, the inverter will shut down. To start operating after this fault, the inverter would need to be restarted (turned back on) after the inverter’s AC loads are reduced/removed.
- **Over-temperature** – If internal power components begin to exceed their safe operating temperature level, the inverter will shut down to protect itself from damage. The inverter’s status LED turns OFF to indicate the over-temperature fault condition. The inverter will automatically restart after the units cools down.
- **Internal Fault** – The inverter continually monitors several internal components and the processor communications. If a condition occurs that doesn’t allow proper internal operation, the inverter will shut down to protect itself and the connected loads. The inverter will need to be reset to start operating.

Table 4-2, Inverter Battery Turn On/Off Levels

Inverter Battery Turn On/Off Levels	Inverter Model
	MMA1212
HBCO	16.0 VDC
HBCI	15.5 VDC
LBCI	≥12.5 VDC
LBCO (one minute delay)	10.0 VDC (9.0 - 12.2 VDC)*
LBCO (immediate)	8.5 VDC

* – Adjustable with ME-RC or ME-ARC remote controls

4.4 Battery Temperature Sensor Operation

The plug-in Battery Temperature Sensor (BTS) is used to determine the temperature around the batteries. This information allows the multi-stage battery charger to automatically adjust the battery charge voltages for optimum charging performance and longer battery life.

When the BTS is installed (Figure 2-6), if the temperature around the BTS is below 77°F (25°C) the absorb and float charge voltage increases. If the temperature around the BTS is higher than 77°F (25°C), the absorb and float charge voltage decreases. See Figure 4-4 to determine how much the charge voltage changes (increases or decreases) as the temperature reading of the BTS changes. For example, the nominal absorb charge voltage for a flooded battery at 77°F (25°C) is 14.6 VDC. If the battery temperature is 95°F (35°C), the absorb charge voltage would decrease to 14.3 VDC (14.6 VDC - 0.3 change).

If the temperature sensor is NOT installed, the charge voltages are not compensated and the battery maintains the charge it had at a temperature of 77°F (25°C). Without a BTS, the life of the batteries may be reduced if they are subjected to large temperature changes.



Info: When the BTS is connected, the battery charger uses a value of $-5\text{mV}/^\circ\text{C}/\text{Cell}$ from 0 to 50°C to change the charge voltage based on temperature.

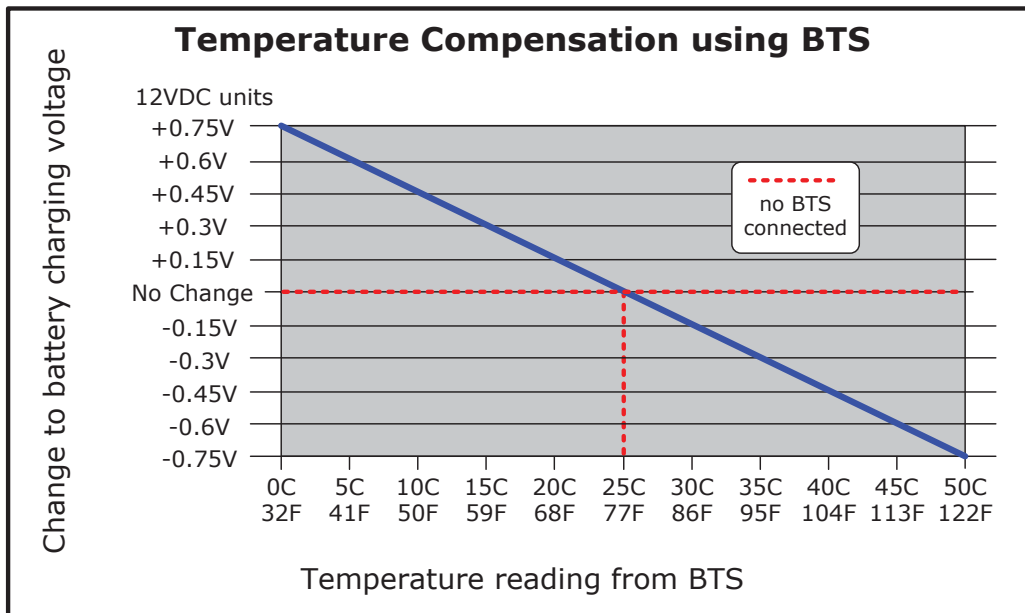

Figure 4-4, Automatic 4-Stage Charging Graph

4.5 Summary of Inverter/DIP Switch Settings

Your MMA1212 inverter uses default settings (established by DIP switch positions) that are adequate for most installations. However, if you determine that some of your operating parameters need to be changed, Sensata offers several remotes (Section 2.5) that allow you to customize the programming parameters of the inverter/charger.

Table 4-3, MMA Inverter/DIP Switch Settings

Function	Settings/Ranges
Inverter/Remote Settings (DIP Switch 1)	UP ¹ = Use Inverter Settings DOWN = Use Remote Settings
Ignition Control (DIP Switch 2)	UP ¹ = Ignition Control Disabled DOWN = Ignition Control Enabled
Ground Control (DIP Switch 3)	UP ¹ = Ground Control Disabled DOWN = Ground Control Enabled
Search Mode ² (DIP Switch 4)	UP ¹ = (Search off) Full AC Output DOWN = Search Mode Activated (5W)
Charge Rate ² (DIP Switch 5)	UP ¹ = 100% (50A) DOWN = 30% (15A)
Battery Type ² (DIP Switches 6 & 7)	Both UP ¹ = Flooded (Absorb = 14.6 VDC, Float = 13.4 VDC) Other DIP settings: AGM1, AGM2, and GEL
Absorb Time ² (DIP Switches 8 & 9)	Both UP ¹ = 60 Minutes Other DIP settings: 90, 120, & 150 minutes
EQ Enable ² (DIP Switch 10)	UP ¹ = EQ Charge Disabled DOWN = Start EQ Charge
LowBatCutOut ²	10.0 VDC ¹
VAC Dropout ²	80 VAC ¹

Note¹: Inverter and DIP switch default settings.

Note²: Optional ME-RC and ME-ARC remote controls provide additional settings for these functions.

5.0 Maintenance & Troubleshooting

The following information is provided to help you keep your MMA1212 inverter/charger in optimum operational condition.

5.1 Recommended Inverter & Battery Care

The MMA1212 inverter is designed to provide you with years of trouble-free service. Even though there are no user-serviceable parts, it is recommended that every six months you perform the following maintenance steps to ensure optimum performance and extend the life of your batteries.



WARNING: Prior to performing these checks, switch both the AC and DC circuits OFF.

- Visually inspect batteries for cracks, leaks, or swelling—replace if necessary
- Use baking soda to clean and remove any electrolyte spills or buildups
- Check and tighten all battery hold down clamps
- Clean and tighten (10 to 12 ft-lbs) all DC terminals (battery and inverter) and connecting cables
- Check/fill battery water levels (Liquid Lead Acid batteries only)
- Check individual battery voltages (replace those that vary more than 0.3 VDC from each other)
- Check all cable runs for signs of chafing—replace if necessary
- Check the inverter’s cooling vents—clean as necessary

5.1.1 Off-Season Storage

If placing a vehicle into seasonal storage, it is recommended that you perform the following to ensure the system is properly shut down (or properly configured for seasonal storage). This is especially important for maintaining the batteries.

- Perform the recommended maintenance steps noted above
- Fully charge the batteries
- Connect shorepower (if available) and verify that the breaker to the battery charger is switched on
- Verify the inverter is switched off
- Switch OFF all unnecessary AC and DC loads

5.2 Troubleshooting

The MMA1212 inverter/charger is a fairly simple device to troubleshoot. There are only two active circuits (AC and DC) as well as a charging circuit. Table 5-1 is designed to help you quickly identify the most common inverter and charger faults.

Table 5-1, Troubleshooting Guide

Symptom	Possible Cause	Recommended Solution
Low Battery Voltage <i>(status indicator blinks on 1 time every 3 secs)</i>	Battery voltage level has dropped below the Low Battery Cut Out (LBCO) set-point for more than one minute (10.0 VDC = LBCO default setting).	Battery voltage too low. Check fuses/circuit-breakers and cable connections. Check battery voltage at inverter's terminals. Batteries may need to be charged—fault condition automatically clears when battery voltage exceeds 12.5 VDC.
High Battery Voltage <i>(status indicator blinks on 2 times every 3 secs)</i>	Battery voltage is above 16.9 VDC. Inverter automatically resets and resumes operation when the battery voltage drops below 16.5 VDC.	Generally, this condition only occurs when an additional charging source (alternator, solar panels or other external charging sources) is used to charge the battery bank. Reduce or turn off any other charger to the inverter batteries to allow the voltage level to drop.
Over-temperature condition <i>(status indicator blinks on 3 times every 3 secs)</i>	Internal temperature of the inverter has risen above acceptable limits—loads too great for inverter to continuously operate or inadequate ventilation around inverter. Once unit has cooled, it automatically resets and resumes operation.	Reduce number of operating electrical loads—will avoid a repeat overtemp shutdown if the cause was too many loads for ambient conditions.
		Check ventilation around the inverter, ensure cool air is available to pass through the inverter.
AC Overload <i>(status indicator blinks on 4 times every 3 secs)</i>	Inverter has turned off because connected loads are larger than the inverter's output capacity—or the output wires are shorted.	Reduce AC loads connected to inverter, or remove all AC output wiring and restart the inverter.

Maintenance & Troubleshooting

Troubleshooting Guide, Cont.

Symptom	Possible Cause	Recommended Solution
Internal fault (<i>status indicator blinks on 5 times every 3 secs</i>)	An internal fault detected.	To clear, perform a power reset by removing DC power to the inverter (see Section 5.3). If the fault does not clear, the unit will need to be serviced.
Inverter's INV status light is off	Inverter is switched OFF, or no DC voltage (battery) connected to inverter.	Switch inverter ON. Connect a battery with correct voltage to inverter.
AC input won't connect (CHG LED remote blinks)	Incoming AC voltage not accepted if below VAC Dropout setting (80 VAC = default).	Check incoming AC voltage to inverter's input, ensure it is present and above the <i>VAC Dropout</i> setting.
Appliances turn off and on, or there is low AC output power	Loose AC output connections.	Tighten AC output connections.
	Loose/corroded battery cables.	Clean and tighten all cables.
	Low batteries.	Recharge or replace batteries.
Inverter AC output voltage too low or too high (using AC voltmeter)	Wrong type of voltmeter used (will display 90 VAC to 130 VAC depending on the battery voltage).	Most meters are made to read average AC voltage.
While charging, the DC charge voltage is higher or lower than expected	If the Battery Temperature Sensor is installed, it will increase or decrease the DC voltage level depending on the temperature around the battery sensor.	This is normal.

5.3 Performing an Inverter Reset

To perform an inverter reset (also known as a “soft reset”):

1. Remove all AC power (i.e., shorepower) to the inverter.
2. Press and hold the inverter’s ON/OFF pushbutton for approximately 10 seconds, or until all LEDs come on in sequence from the first (INV) to the last (FAULT).
3. Release the ON/OFF pushbutton once all LEDs turn off.
Note: LEDs will cycle every 10 secs if the button is NOT released.
4. Press the ON/OFF pushbutton again to turn the inverter on.



Info: The ON/OFF pushbutton is a small momentary type switch which is operated by lightly pressing and releasing.

If an inverter reset fails, perform a power reset using the procedure below. If the internal fault still does not clear, the inverter may require repair at an Authorized Service Center (ASC).

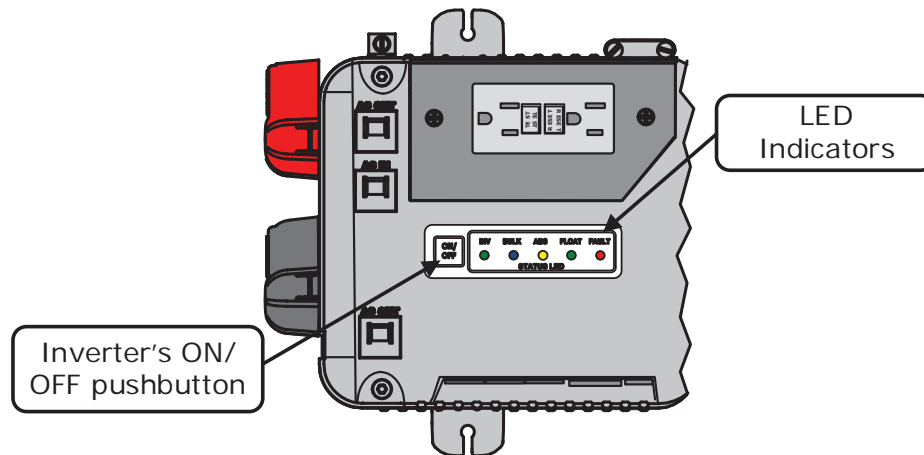

Figure 5-1, Resetting the Inverter

5.4 Performing a Power Reset

To perform a power reset (also known as a “hard reset”):

1. Remove all AC power (i.e., shorepower) to the inverter.
2. Open all the inverter DC disconnects (or disconnect the positive battery cable to the inverter).
3. Ensure the inverter and the remote are disconnected from all AC and DC power (the remote display will be blank).
4. After the inverter has been disconnected from all power for 30 seconds, reconnect the inverter DC disconnects (or reconnect the positive battery cable) and resume operation.



Info: If no DC disconnects in system, a momentary spark may occur when the positive battery cable is connected to the inverter’s terminal. This is normal and indicates the inverter’s internal capacitors are being charged.

Specifications

6.0 Specifications

Table 6-1, MMA1212 Specifications

MODEL:	MMA1212
Inverter Specifications	
Input battery voltage	9 to 16 VDC
Nominal AC output voltage	120 VAC +/- 5%
Output frequency and accuracy	60 Hz +/- 0.1 Hz
1 msec surge current	40 AAC
100 msec surge current	21 AAC
5 sec surge power	2200 W
30 sec surge power	2000 W
5 min surge power	1900 W
30 min surge power	1350 W
Continuous power output @ 45°C	1200 VA
Max. continuous input current	160 ADC
Inverter efficiency (peak)	87%
Transfer time	16 msec
AC pass-thru capability	15 A
Search mode (typical, no remote)	5 W
No load (typical, no remote)	22 W
Output AC waveform type	Modified Sine Wave
Charger Specifications	
Continuous output at 45°C	60 ADC
Charger efficiency (maximum)	84%
Power factor	> 0.95
Input current @ rated output	8.5 AAC
Temperature compensation	Yes, with BTS
General Features and Capabilities	
Protection circuitry	Low/High Battery, Over-temp & Overload
Corrosion protection	PCB's conformal coated, powder coated chassis
AC output	GFCI outlet
AC input	3 ft cord
Output circuit breaker	15 A
Input circuit breaker	20 AAC
AUX output circuit breaker	20 AAC
Internal cooling	Yes, 0 to 59 cfm variable speed
UL listing	ETL to UL/cUL458, CSA C22.2 #107.1-01
Environmental Specifications	
Operating temperature	-20° C to +60° C (-4° F to 140° F)
Non-operating temperature	-40° C to +70° C (-40° F to 158° F)
Operating humidity	0 to 95% RH non-condensing
Physical Specifications	
Dimensions (L x W x H)	16.75"x 8.5"x 6.75" (42.5 cm x 21.6 cm x 17.1 cm)
Mounting	Shelf or wall (top or bottom up)
Weight	24 lbs. (10.9 kg)
Shipping weight	25 lbs. (11.3 kg)

Specifications @ 45°C unless otherwise noted – Subject to change without notice

Appendix A – Optional Equipment & Accessories

The following components are available for use with the MMA1212 inverter/charger. Some of these items are required depending upon the intended use of the inverter.

Smart Battery Combiner

The Smart Battery Combiner (ME-SBC™) is designed to monitor and charge a second battery using a portion of the current that is charging the main battery. The ME-SBC eliminates a significant voltage drop, and provides automatic turn-on and turn-off based on adjustable voltage set-points. This allows different batteries to be charged from a single charging source, and prevents overcharging/undercharging.

Auto Generator Start Controller

The ME-AGS-N Automatic Generator Start controller (Network version) is designed to automatically start your generator based on low battery condition or high temperature. It works with 12, 24, and 48-volt battery banks and includes a 4-position DIP (Dual In-line Package) switch which provides the ability to change the relay timing configurations to allow compatibility with most generators.

Battery Monitor Kit

The ME-BMK Battery Monitor Kit is a single battery bank amp-hour meter that monitors the condition of the battery and provides information to let you know how much energy you have available and to plan your electrical usage to ensure the battery is not being over-discharged. The ME-BMK-NS version does not include a DC shunt—order the ME-BMK to receive a 500A/50mv DC shunt.

Fuse Block/Fuses

The fuse/fuse-blocks are used to protect the battery bank, inverter, and cables from damage caused by DC short circuits and overloads. They include a slow-blow fuse with mounting block and protective cover. The 125 and 200-amp models use an ANL type fuse and the 300 and 400-amp models use a Class-T fuse.

Appendix B – Battery Information

B-1 Battery Bank Sizing

The size of the battery bank determines how long the inverter can power the AC loads without recharging. The larger the battery bank, the longer the run time. Size your battery bank to the system's AC load requirements and the length of time required to run the load from the batteries. In general, the battery bank should not be discharged more than 50%.

B-2 Battery Types

Batteries are available in different sizes, amp-hour ratings, voltage, and chemistries; they also come in liquid or gel, vented or non-vented, etc. They are also available for starting applications (i.e., an automobile starting battery) and deep discharge applications. Only the deep cycle types are recommended for inverter applications. Choose the batteries best suited for the inverter installation and cost. Use only the same battery type for all batteries in the bank. For best performance, all batteries should be from the same lot and date. This info is usually printed on a label located on the battery.

B-3 Battery Configuration

The battery bank must be wired to match the inverter's DC input voltage specifications (12 VDC). In addition, the batteries can be wired to provide additional run time. The various wiring configurations are:

Series Wiring

Wiring batteries in a series increases the total battery bank output voltage. A series connection combines each battery in a string until the voltage matches the inverter's DC requirement. Even though there are multiple batteries, the capacity remains the same. In the example below (Figure B-1), two 6 VDC/200 AH batteries are combined into a single string—resulting in a 12 VDC/200 AH bank.

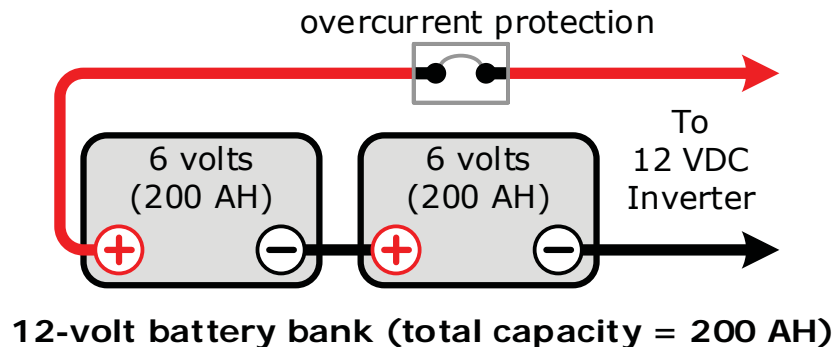

Figure B-1, Series Battery Wiring

Parallel Wiring

Wiring the batteries in parallel increases the total run time the batteries can operate the AC loads. A parallel connection combines overall battery capacity by the number of batteries in the string. Even though there are multiple batteries, the voltage remains the same. In the example below (Figure B-2), four 12 VDC/100 AH batteries are combined into a single 12 VDC/400 AH battery bank.

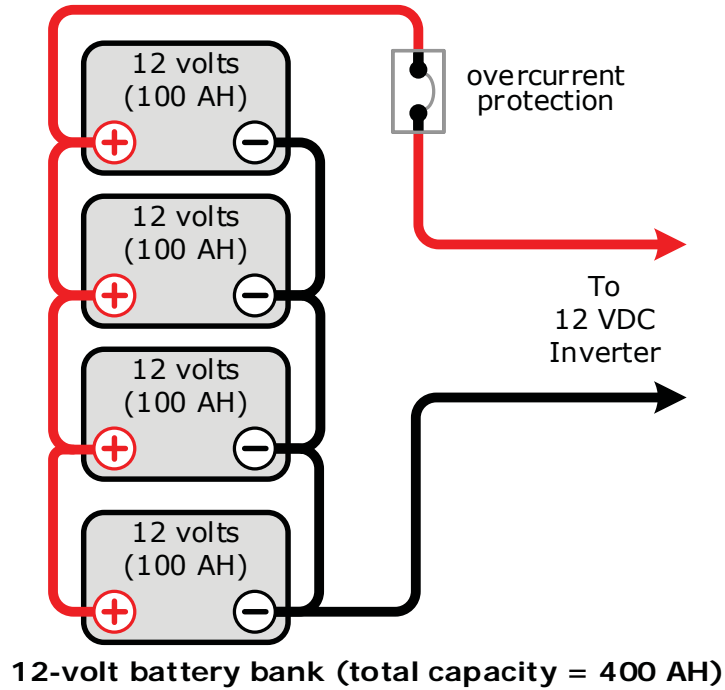

Figure B-2, Parallel Battery Wiring

Series-Parallel Wiring

A series-parallel configuration increases both voltage (to match inverter's DC requirements) and capacity (to increase run time for operating loads) using smaller, lower-voltage batteries. In example below (Figure B-3), four 6 VDC/200 AH batteries are combined into two strings resulting in a 12 VDC/400 AH battery bank.

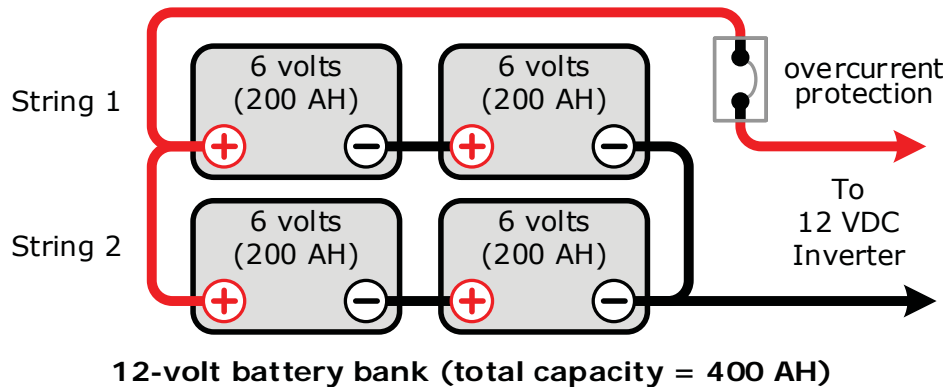

Figure B-3, Series-Parallel Battery Wiring

Appendix B – Battery Information

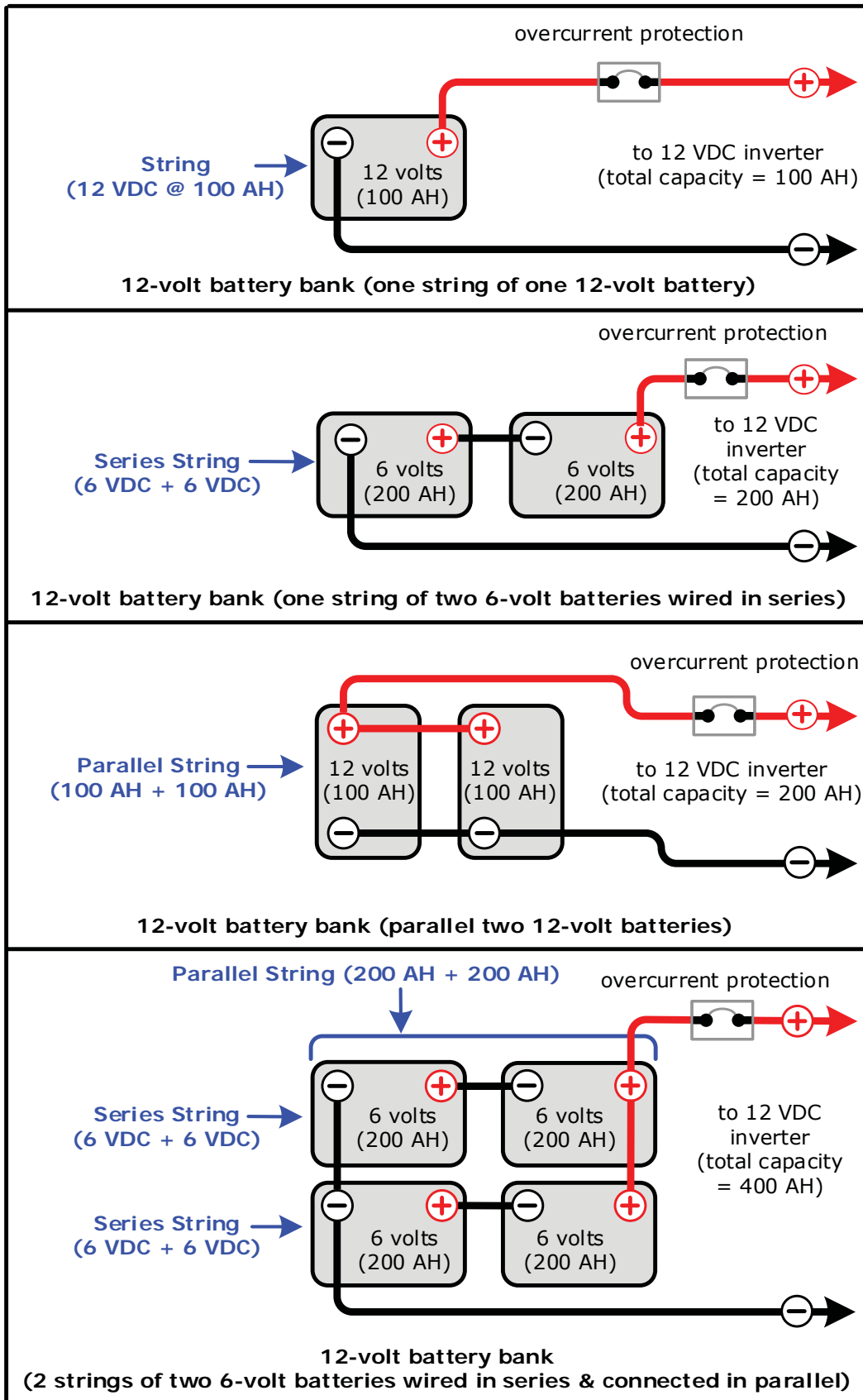

Figure B-4, Battery Bank Wiring Examples

Appendix C – Warranty/Service Information

C-1 Warranty Information

Sensata Technologies warrants the MMA1212 inverter/charger to be free from defects in material and workmanship that result in product failure during normal usage, according to the following terms and conditions:

1. The limited warranty for the product extends for 24 months beginning from the product's original date of purchase.
2. The limited warranty extends to the original purchaser of the product and is not assignable or transferable to any subsequent purchaser.
3. During the limited warranty period, Sensata will repair or replace (with factory new or rebuilt replacement items) at Sensata's option any defective parts, or any parts that will not properly operate for their intended use—if such repair or replacement is needed because of product malfunction or failure during normal usage. The limited warranty does not cover defects in appearance (cosmetic or decorative), or any structural or non-operative parts. Sensata's limit of liability under the limited warranty shall be the actual cash value of the product at the time the original purchaser returns the product for repair, determined by the price paid by the original purchaser. Sensata shall not be liable for any other losses or damages.
4. Upon request from Sensata Technologies, the original purchaser must prove the product's original date of purchase by a dated bill of sale, itemized receipt.
5. The original purchaser shall return the product prepaid to Sensata in Everett, WA, or to one of Sensata's Authorized Service Centers (ASC). After the completion of service under this limited warranty, the product will be returned prepaid to the original purchaser via a non-expedited surface freight within the contiguous U.S. and Canada; this excludes Alaska and Hawaii.
6. If Sensata repairs or replaces a product, its warranty continues for the remaining portion of the original warranty period or 90 days from the date of the return shipment to the original purchaser, whichever is greater. All replaced products and parts removed from repaired products become the property of Sensata Technologies.
7. This limited warranty is voided if:
 - the product has been modified without authorization
 - the serial number has been altered or removed
 - the product has been damaged through abuse, neglect, accident, high voltage, or corrosion
 - the product was not installed and operated according to the owner's manual

A RETURN MATERIAL AUTHORIZATION (RMA) NUMBER IS REQUIRED BEFORE RETURNING ANY PRODUCT

C-2 How to Receive Repair Service

If your product requires warranty service or repair, contact either:

- An authorized service center, at www.Magnum-Dimensions.com, or,
- Sensata Technologies at:
 - Telephone: 425-353-8833
 - Fax: 425-353-8390
 - Email: MagnumWarranty@Sensata.com

If returning your product directly to Sensata for repair, you must:

1. Return the unit in the original, or equivalent, shipping container.
2. Receive a Return Materials Authorization (RMA) number from the factory prior to the return of the product to Sensata for repair.
3. Place RMA numbers clearly on the shipping container or on the packing slip.

When sending your product for service, please ensure it is properly packaged. **Damage due to inadequate packaging is not covered under warranty.** We recommend sending the product by traceable or insured service.



Magnum-Dimensions Products

Manufactured by:

Sensata Technologies

2211 West Casino Rd.

Everett, WA 98204

Phone: (425) 353-8833

Fax: (425) 353-8390

Web: www.Magnum-Dimensions.com