

## ME-AGS wiring diagram – For Lister Petter Generator (GS Series Diesel with remote start)

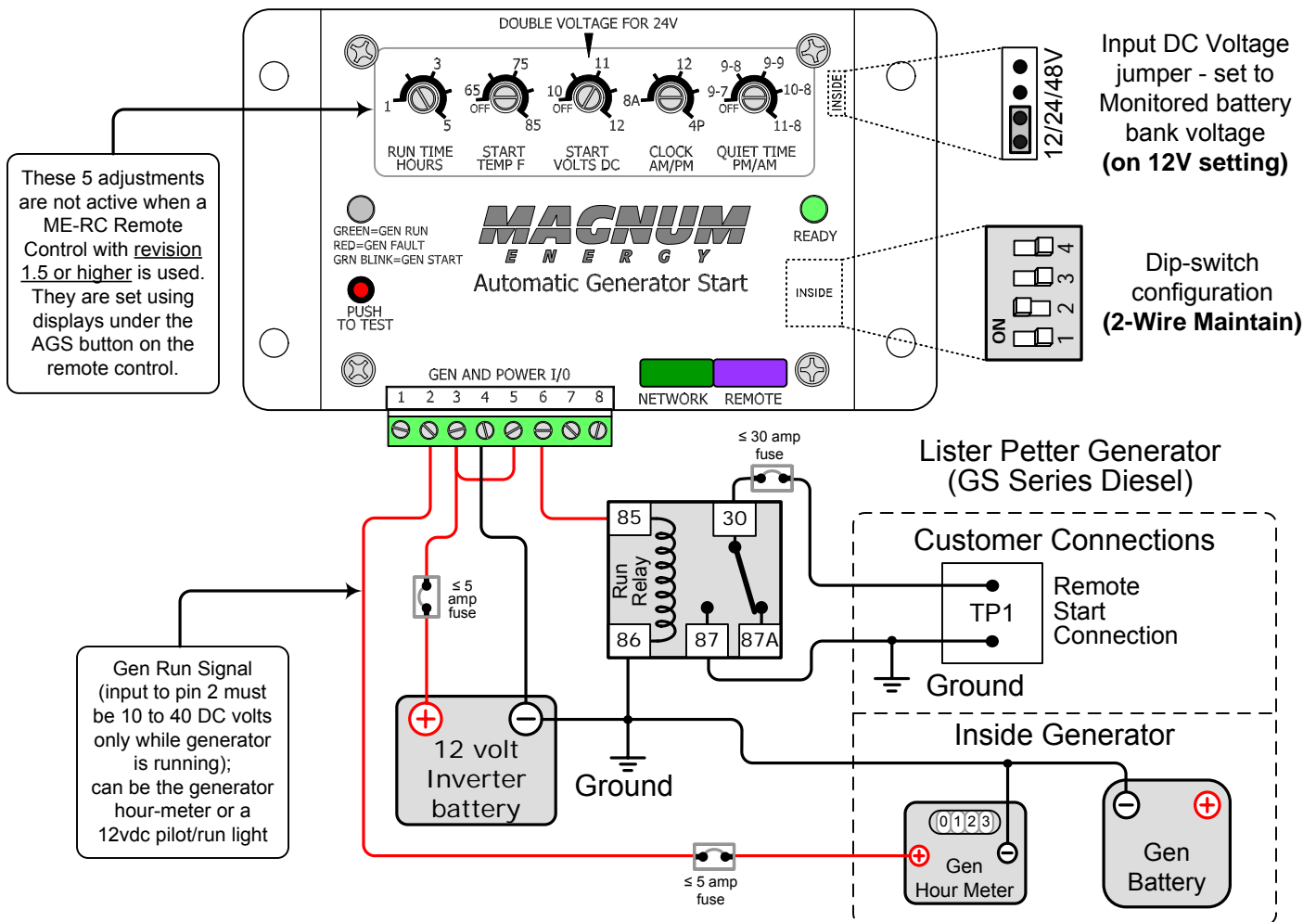

Relay used is a SPDT 30 Amp, 12 VDC coil relays [shown in the non-energized (N.C.) position]; popular in automotive sound and security installations. Equivalent to Bosch #0 332 209 150. Mfg. #V23234-A1001-X036.

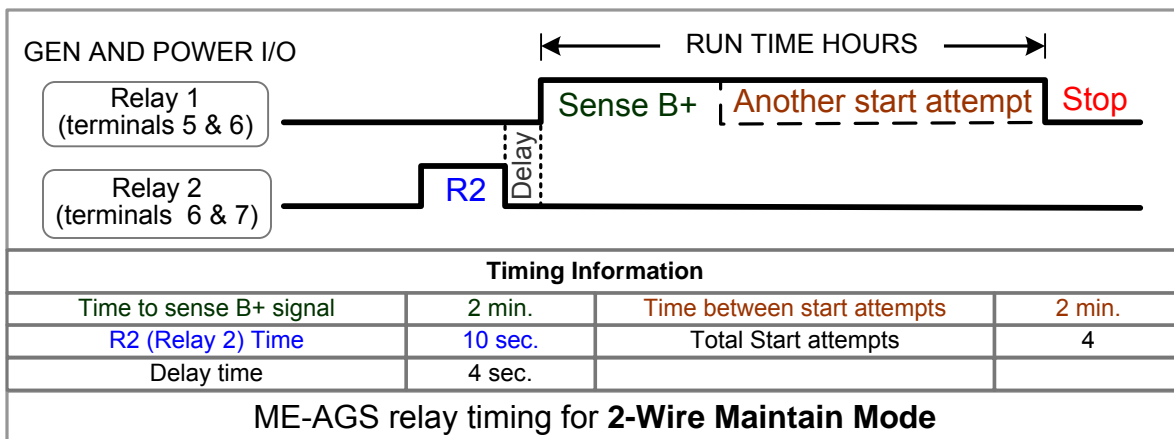

Magnum Energy, Inc. provides this diagram to assist in the installation of the Auto-Generator Start controller. Since the use of this diagram and the conditions or methods of installation, operation and use are beyond the control of Magnum Energy, Inc., we do not assume responsibility and expressly disclaim liability for loss, damage or expense arising out of the installation, operation and use of this unit.