

ME-AGS-N wiring diagram – For Generac Home Standby Generators [PowerPact™ Controller (2014 and later)]

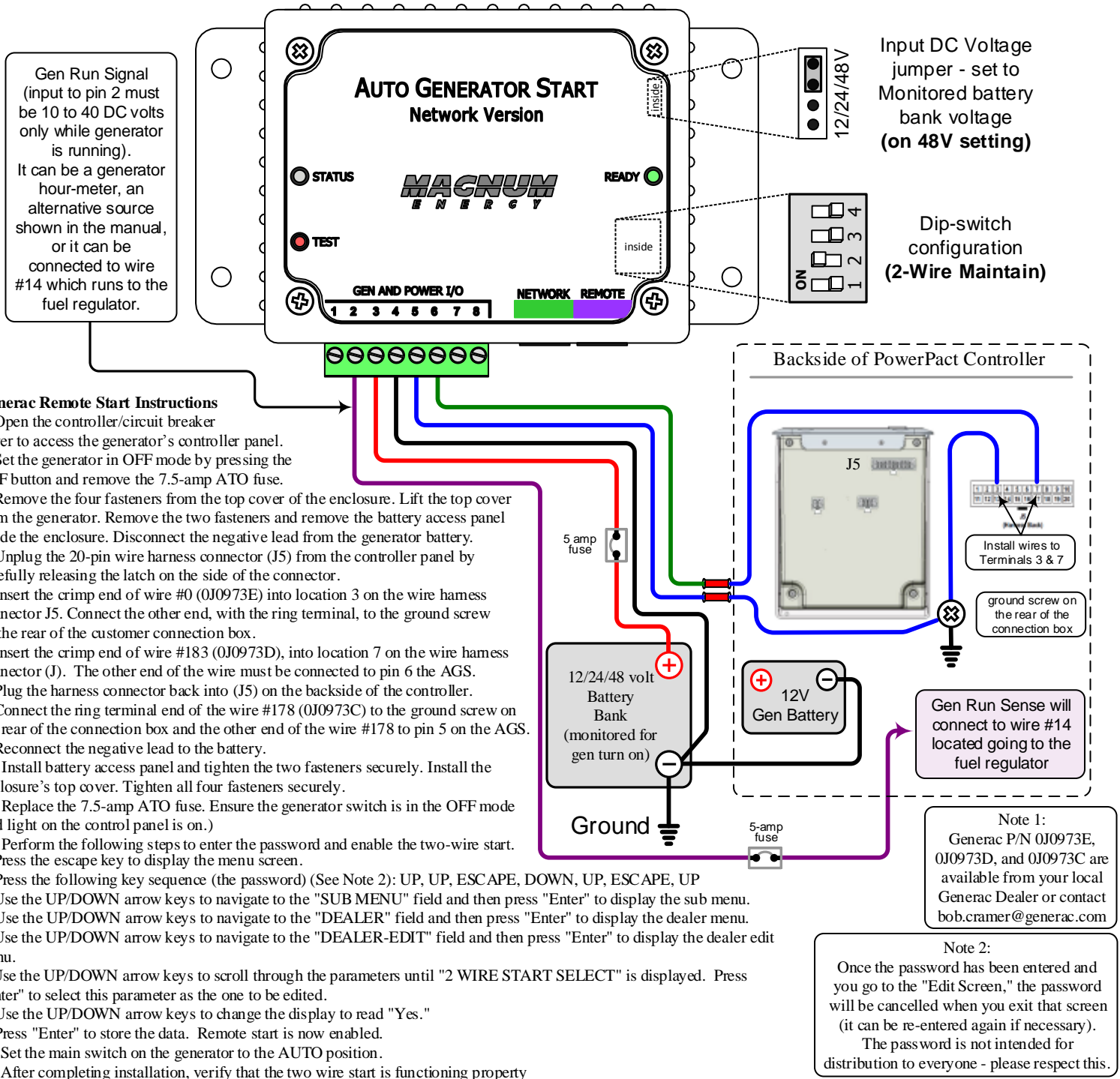

	<table border="1"> <tr> <td>Time to sense 'Gen Run' signal</td> <td>2 Min.</td> </tr> <tr> <td>R2 Time</td> <td>10 Sec.</td> </tr> <tr> <td>Delay Time</td> <td>2 Sec.</td> </tr> <tr> <td>Time Between Start attempts</td> <td>2 min.</td> </tr> <tr> <td>Total Start Attempts</td> <td>4</td> </tr> </table>	Time to sense 'Gen Run' signal	2 Min.	R2 Time	10 Sec.	Delay Time	2 Sec.	Time Between Start attempts	2 min.	Total Start Attempts	4
Time to sense 'Gen Run' signal	2 Min.										
R2 Time	10 Sec.										
Delay Time	2 Sec.										
Time Between Start attempts	2 min.										
Total Start Attempts	4										

Magnum Energy, Inc. provides this diagram to assist in the installation of the Auto-Generator Start controller. Since the use of this diagram and the conditions or methods of installation, operation and use are beyond the control of Magnum Energy, Inc., we do not assume responsibility and expressly disclaim liability for loss, damage or expense arising out of the installation, operation and use of this unit.