

**Sensata**  
Technologies

4467 White Bear Parkway  
St. Paul, MN 55110  
Phone: 651-653-7000, 800-553-6418  
Fax: 651-653-7600, 888-439-3565  
[inverterinfo@sensata.com](mailto:inverterinfo@sensata.com)  
[www.dimensions.sensata.com](http://www.dimensions.sensata.com)

**Owner's Manual**

**Oct 2012**

**ISO 9001:2000 Registered Company**

**DIMENSIONS™**

**DC to AC Standby Power System**

Model:

**12U12**

Including Options:

- A:** Emergency Vehicles
- B3:** 3-Step Battery Charger
- R:** LED Remote Status Panel
- R1:** LCD Remote Control/Status Panel  
with master disconnect
- R2:** Remote "On/Off" Switch - Ground Start
- R4:** LCD Remote Control/Status Panel
- T:** Transfer Switch
- U:** Utility Vehicles

## Table of Contents:



Section	Description	Page
<b>1</b>	<b>Safety Instructions</b> .....	<b>3</b>
1.1	Warning and Danger Symbols .....	3
1.2	Inverter Precautions .....	3
1.3	Battery Precautions .....	3
<b>2</b>	<b>Specifications</b> .....	<b>4</b>
<b>3</b>	<b>Technical description</b> .....	<b>5</b>
3.1	Standby Power Systems .....	5
3.1.1	Inverter Power Mode .....	5
3.1.2	External Power Mode .....	5
<b>4</b>	<b>SPS Physical description</b> .....	<b>6</b>
4.1	SPS Module .....	6
<b>5</b>	<b>Available Options</b> .....	<b>7</b>
5.1	Emergency Vehicles – “A” Option .....	7
5.2	Battery Charger – “B3” Option .....	8
5.3	LED Remote Status Panel – “R” Option .....	8
5.4	LCD Remote Control/Status Panel – “R4” Option .....	9
5.5	LCD Remote Control/Status Panel – “R1” Option .....	9
5.6	Remote “On/Off” Switch, Ground Start - “R2” Option .....	9
5.7	Transfer Switch – “T” Option .....	10
5.8	Utility Vehicles – “U” Option .....	10
<b>6</b>	<b>Installation</b> .....	<b>11</b>
6.1	Tools Needed for Installation .....	11
6.2	System Components .....	11
6.3	Mounting the SPS .....	11
6.3.1	Chassis Bonding Lug .....	11
6.3.2	Temperature Compensation Sense Probe .....	11
<b>7</b>	<b>SPS Wiring</b> .....	<b>12</b>
7.1	DC Wiring .....	12
7.1.1	Inverter Cable .....	12
7.1.2	Charge Cable .....	12
7.1.3	Connecting the DC Wires .....	13
7.1.4	Remote “On/Off” Switch .....	13
7.1.5	Remote “On/Off” Switch, Ground Start - “R2” Option .....	13
7.1.6	Deep Cycle Batteries .....	14
7.2	AC Wiring .....	14
7.2.1	AC Output .....	14
7.2.2	AC Input .....	14
7.3	DC Wiring Diagram .....	15
7.4	AC Wiring Diagram .....	17
<b>8</b>	<b>Operation and Troubleshooting</b> .....	<b>18</b>
8.1	Operation .....	18
8.1.1	Setting the Battery Size and Type .....	18
8.1.2	Turning the SPS On .....	18
8.2	Troubleshooting .....	19
<b>9</b>	<b>Warranty</b> .....	<b>20</b>

# 1 Safety Instructions

**Important:** Read this manual before installation, it contains important safety, installation, and operating instructions. Save this manual and keep it in a safe place.

## 1.1 Warning and Danger Symbols:

To reduce the risk of electrical shock and to ensure the safe operation of your Dimensions power inverter, the following symbols are used throughout the manual.

<p><b>ATTENTION:</b></p>  <p>Important operating instructions. Follow them closely.</p>	<p><b>DANGER:</b></p>  <p>Risk of personal harm and/or electrocution exists in this area. Use extreme caution.</p>

## 1.2 Standby Power System Precautions:

- Standby Power Systems produce hazardous voltages. To avoid risk of harm or fire, the unit must be properly installed.
- There are no user serviceable parts inside, do not remove the cover.
- The Standby Power Systems should not be mounted in a location that may be exposed to rain or spray.
- The Standby Power Systems should not be installed in a zero clearance enclosure.
- Damage to the Standby Power Systems will occur if correct polarity is not observed when installing the DC input cables.
- Damage to the Standby Power Systems will occur if an external AC power source is applied to the inverter's AC hardwire output.
- The Standby Power Systems contains a circuit breaker and capacitor that may produce a spark. Do not mount in a confined battery or gas compartment.
- Be sure the Standby Power Systems is turned OFF during installation.

## 1.3 Battery Precautions:

- Working in the vicinity of lead-acid batteries is dangerous. There is a risk of acid exposure.
- Batteries generate explosive gases during operation.
- There is risk of high current discharge from shorting a battery that can cause fire and explosion. Use insulated tools during installation.
- Remove all rings, watches, jewelry or other conductive items before working near the batteries.
- Inspect the batteries once a year for cracks, leaks or swelling.
- Dispose of the batteries according to local regulations. Do not incinerate batteries; risk of explosion exists.

## 2 Specifications

### Millennium Series Standby Power Systems

**12U12**

<b>Output Voltage (VAC)</b>	120 RMS $\pm$ 5%
<b>Output Frequency:</b>	60 Hz $\pm$ 0.05%
<b>Output Waveform:</b>	Quasi-sine wave, with waveform stabilizer
<b>Input Voltage: (VDC)</b>	10.5 to 20
<b>Operating Temperature:</b>	-20° to 40° C (0° to 104° F)
<b>Efficiency:</b>	Up to 93%

**Environmentally Friendly,  
Quiet, Reliable, AC Power**

#### Other Design Features:

- Thermally-controlled cooling fan.
- GFCI outlet protection.
- Enclosed AC and DC cable connections with strain relief.
- Remote ON/OFF switch hookup.
- LED display for Inverter Power, Low battery, High temperature, & Overload ("U" option).
- Battery voltage indicator with push-to-test ("U" option).
- Optional Battery Charger "B3" and Transfer Relay "T".
- Optional remote LED display for Inverter Power, Low battery, High temperature, & Overload ("R" option).
- Optional one wire ground start ("R2" option).
- Optional remote LCD display with 21 user-friendly messages "R4" option ("R1" option includes master disconnect).

#### Unit Protection:

- Automatic electronic short circuit/overload protection
- Automatic high temperature shutdown
- Output circuit breakers

#### Battery Protection:

Automatic low battery shutdown at 10.5 VDC (with in-rush delay)

<b>MODEL NUMBER</b>	<b>12U12</b>
<b>Output Power</b> (Watts Cont.)	1,200
<b>Output Current</b> (Amps AC)	Up to 10
<b>Peak Output</b> (Amps AC)	30
<b>Output Rating:</b> (hp)	¼
<b>Input Current</b> (Amps DC)	Up to 120
<b>Weight</b> (lbs.)	27
<b>Dimensions</b> LxWxH – (In.)	13¼ x 11 x 6¾
<b>BATTERY CHARGER "B3"</b> <b>(Optional)</b>	3 step charger with automatic conditioning; Temperature compensated output voltage; selectable between wet and sealed lead acid batteries; selectable between small and large battery banks
<b>Output Current</b> (Amps DC)	55
<b>Input Current</b> (Amps AC)	Up to 13
<b>TRANSFER RELAY "T"</b> <b>(Optional)</b>	Fail-safe shore power Transfer Relay
<b>Current Rating</b> (Amps AC)	30
<b>Transfer Time</b> (milliseconds)	Less than 16 typical

**Usage:** Any 120 VAC, 60 Hz single-phase products within the standby power system's rating that does not require a pure sine waveform.

## 3 Technical Description

### 3.1 Standby Power System:

A Standby Power System is a DC to AC power inverter with a battery charger ("B3" option) and an automatic fast transfer switch ("T" option).

**Note:** In this manual, we will use the acronym SPS when referring to a Standby Power System.

The "On/Off" switch controls the SPS and the LED lights built on the front of the SPS provides system status. The SPS can also be controlled by a customer supplied remote "On/Off" switch connected to the violet wire labeled "remote switch hook-up" located in the field-wiring compartment.

The system has two operational modes when the transfer switch "T" option is included: Inverter mode and external power mode.

**3.1.1 Inverter Power Mode:** The SPS converts DC power from batteries to usable 120 VAC, 60 Hz power. The direct current (DC) that enters the SPS is filtered by a large input capacitor and switched "On" and "Off" by Metal Oxide Silicon Field Effect Transistors (MOSFET) at a rate of 60 cycles per second, and directed into the transformer which steps the voltage up to 120 volts. The unit has a Digital System Processor (DSP) to control the output voltage and frequency as the DC input voltage and/or output load varies. The quasi-sine output waveform shape is not sinusoidal; it has a total harmonic distortion of 31% and a maximum single harmonic distortion of 25%.

**3.1.2 External Power Mode – "T" option only:** 120 VAC, 60 Hz external power can be applied directly to the SPS by hardwire connections to the AC input wire leads provided in the field-wiring compartment (available with the "T" option only). When external power is present, the internal transfer switch cannot be defeated; it automatically turns the DC to AC inverter OFF and activates the three-step battery charger if the "B3" option is included. At this time the loads attached to the SPS output will operate directly from the external power line even if the SPS was turned OFF manually. The internal transfer relay automatically switches the SPS back to "inverter power" mode in the absence of external power whenever the SPS was previously set to ON.

## 4 SPS Physical Description

### 4.1 SPS Module

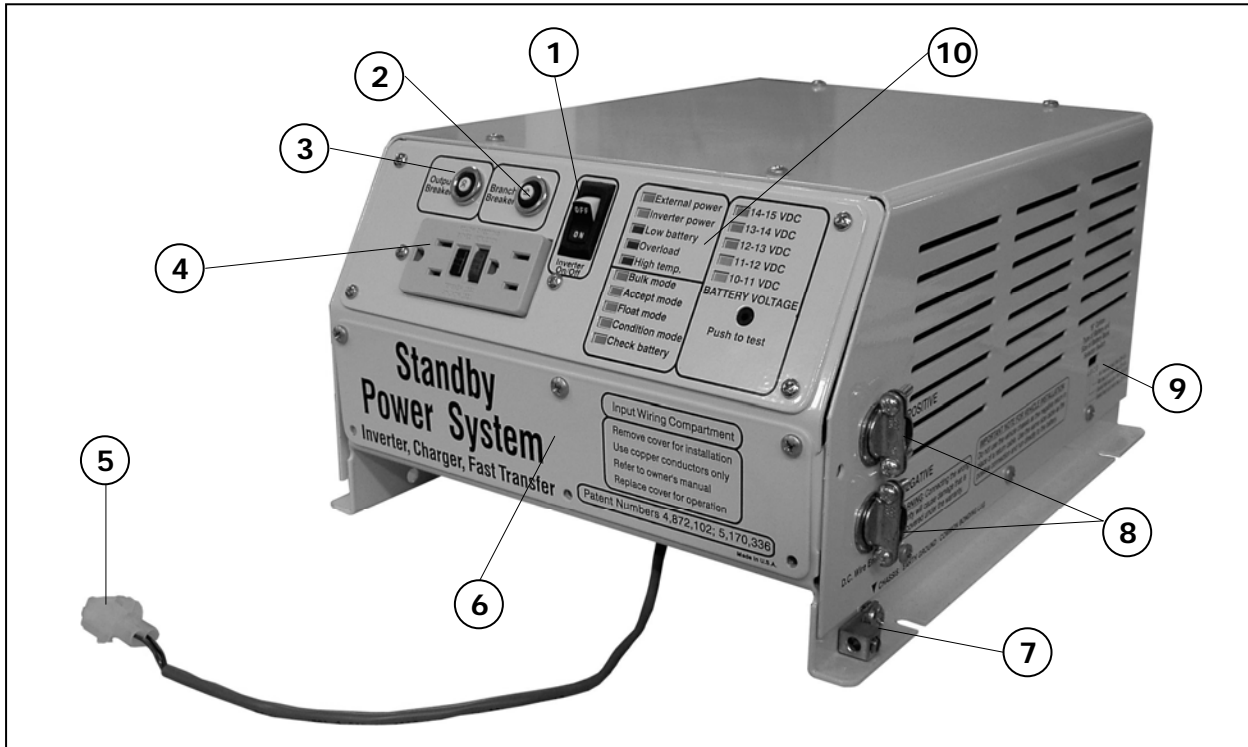

FIGURE 1: SPS module physical description

Item #	Description	Function
1	"On/Off" Switch.	Turns the SPS ON/OFF
2	Branch Breaker	Trips to protect the SPS from GFCI outlet short circuit or overload.
3	Output Breaker	Trips to protect the SPS from hardwire AC output short circuit or overload.
4	GFCI Outlets	Two outlets, output power 120 VAC 60 Hz.
5	Temp. Comp. Probe Connector	Connects to the remote temperature sense probe. Available with the "B3" option only.
6	Field Wiring Compartment Cover	Removeable to access the AC Input/Output lead wires and DC field-wiring compartment.
7	Bonding Lug	Connects to the ground system.
8	DC input entry opening	Allows the DC cables to reach the DC input terminal connector.
9	Battery Capacity Selector Switch	Sets the correct battery type and the capacity of the battery bank for proper charging. Available with "B3" option only.
10	LED Status Panel	Provides system status – See Section 5 for display options.

## 5. Available Options

### 5.1 Emergency Vehicles – “A” Option:

The SPS has only one AC output circuit with one output breaker. The 120VAC 60Hz AC outlets and the set of hardwire leads are both GFCI protected with the “A” option. All SPS having the “A” option come with a front panel On/Off switch (Figure 1, Item 1) and a LED Front Status Panel (Figure 2).

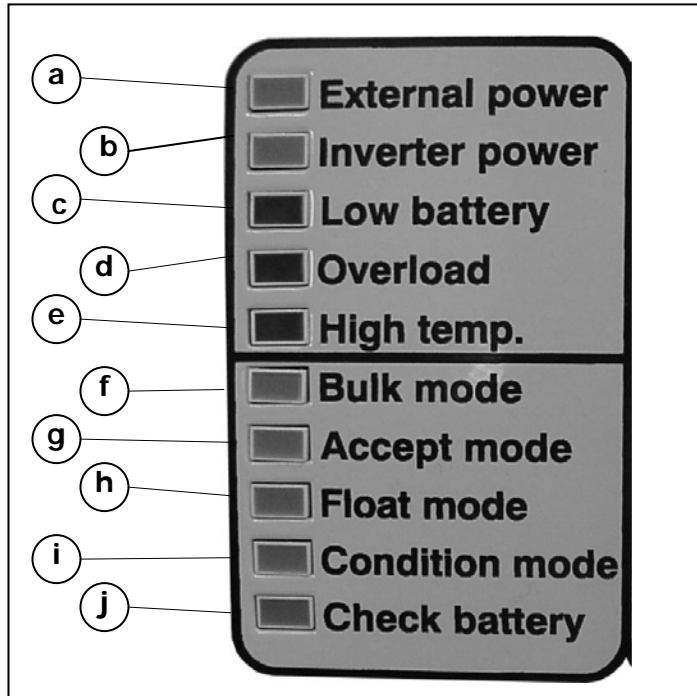

FIGURE 2: LED Front Status Panel – “A” Option

- (a) **External power – “T” option:** The green LED indicates that there is external 120 VAC, 60 Hz connected to the unit.
- (b) **Inverter power:** The green LED indicates that the SPS is operating from batteries in “inverter mode”.
- (c) **Low battery:** The red LED indicates that the SPS is in a low battery voltage condition.
- (d) **Overload:** The red LED indicates that the SPS is in an overload condition.
- (e) **High temp:** The red LED indicates that the SPS has a high internal temperature.
- (f) **Bulk mode – “B3” option:** The green LED indicates that the battery charger is in the bulk mode.
- (g) **Accept mode – “B3” option:** The green LED indicates that the battery charger is in the acceptance mode.
- (h) **Float mode - “B3” option:** The green LED indicates that the battery charger is in the float mode.
- (i) **Condition mode - “B3” option:** The green LED indicates that the battery charger is in the condition mode. Available with the “B3” option only.
- (j) **Check battery - “B3” option:** The yellow LED indicates a possible fault in the battery bank or DC cables.

### 5.2 Battery Charger – “B3” Option:

The three-step battery charger requires the transfer switch “T” option to operate. External power 120 VAC, 60 Hz is applied as explained in section 3.1.2 The internal transfer switch automatically turns the DC to AC inverter OFF and turns the three-step built-in battery charger ON. The battery charger cannot be defeated at this time and will engage even if the inverter has been set OFF manually.

The 3-steps of the charging process are as follows:

**Bulk mode:** Charging current is passed through the batteries until a factory set acceptance voltage limit is reached. The charger’s maximum output and/or the state of charge of the batteries determine the amount of current.

**Acceptance mode:** Charging continues with the voltage held at the accept voltage until current flow decreases to the factory set end value or the factory set acceptance mode time limit is reached.

**Float mode:** Battery voltage is held at a factory set value, which will neither charge nor discharge the batteries.

**Condition mode:** Occurs every 10<sup>th</sup> charge cycle between Acceptance mode and Float mode to ensure full restoration of active materials in all the plates of the battery cells.

The SPS has an automatic power sharing feature that automatically decreases the battery charger output so that the total AC input of the SPS for both the AC loads and the battery charger does not exceed the 30 amp input circuit breaker. If the loads exceed 30 amps the charger will be at zero amp draw and the input circuit breaker will trip. The battery charger draw will automatically increase when the external loads are reduced if the batteries will accept more current.

### 5.3 LED Remote Status Panel – “R” Option:

If the “R” option is included, a Remote Status Display Panel is supplied as shown in Figure 3. The LEDs have the same functions as in Section 5.1, Figure 2, Items a through e.

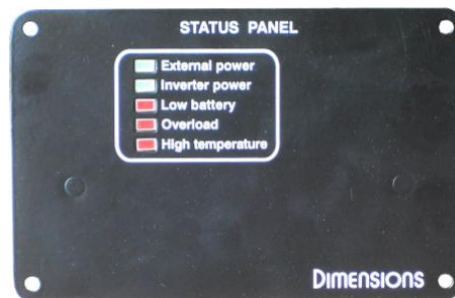

Figure 3 – Remote Display Status Panel, “R” Option



### 5.4 LCD Remote Control/Status Panel - "R4" Option:

Refer to Figure 4. The SPS can only be controlled by the remote control/status panel, which is connected to the SPS module by a gray flat 8-conductor wire. There are three push buttons and a red LED that when lit indicates a trouble condition. The remote control/status panel provides system status through a 16-character by 2 line LCD display.

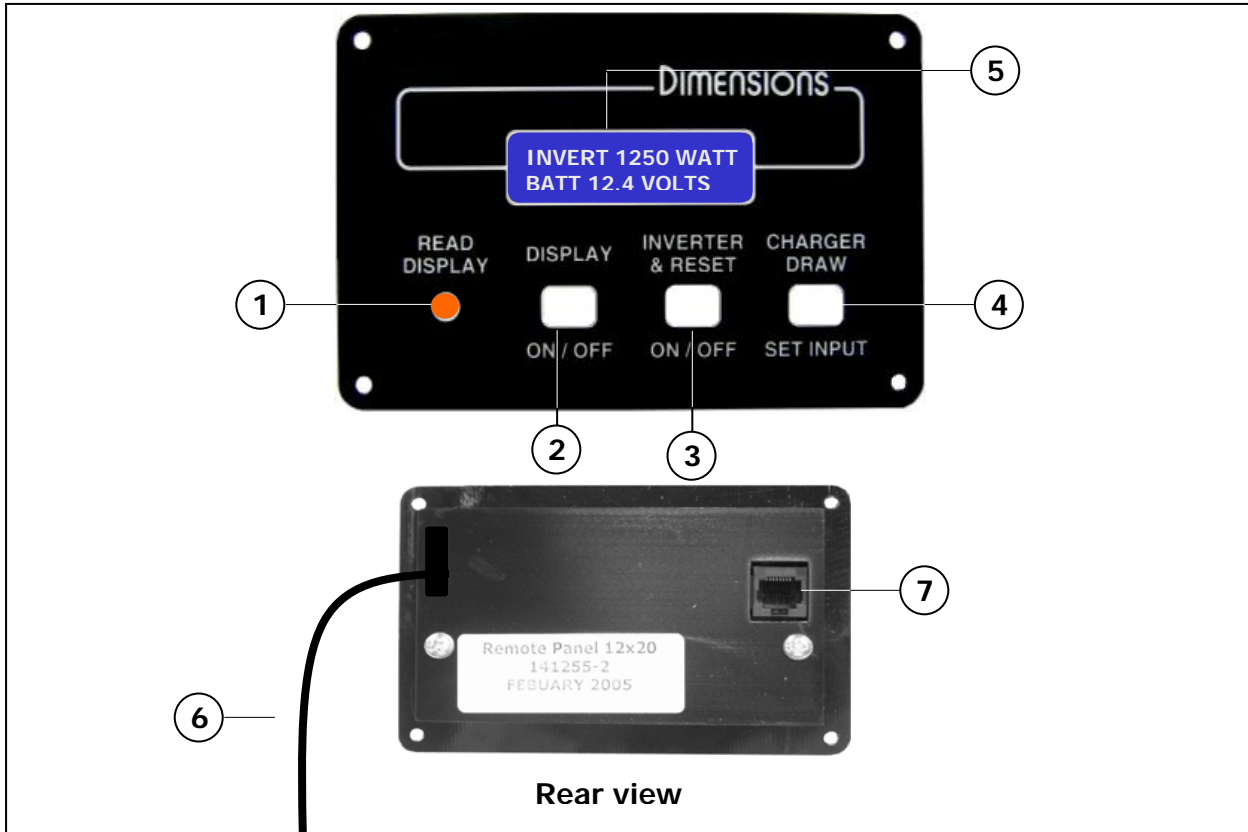

FIGURE 4: LCD Remote Control/Status Panel

- 1 **Read Display:** The red LED indicator will light when the SPS is in a warning condition.
- 2 **Display – On/Off:** Turns the LCD screen backlighting ON or OFF.
- 3 **Inverter & Reset – On/Off:** Turns the SPS ON or OFF and resets any error message.
- 4 **Charger draw – Set Input:** This button limits the input AC current for the battery charger.
- 5 **LCD Display:** Shows system status, battery voltage, and electrical current in both inverter and external power mode as well as shut down conditions.
- 6 **DC Master Disconnect control wire – "R1" Option:** Available with the LCD Remote Control/Status Panel. A 1-foot, red wire extends from the back of the panel and connects to the "DC master disconnect switch" which is found in many recreational vehicles.
- 7 **Flat cable connector jack:** Connects the 8-conductor flat gray signal cable coming from the SPS.

### 5.5 LCD Remote Control/Status Panel – "R1" Option:

Refer to Figure 4. This option is the same as the "R4" Option except the panel includes a 1-foot control wire extending from the back for DC master disconnect in vehicle.

### 5.6 Remote "On/Off Switch, Ground Start – "R2" Option:

If the "R2" option is included, the SPS can be controlled by a customer supplied remote "On/Off" switch connected to the 18-gauge black wire labeled "remote switch hook-up" which is located in the field-wiring compartment, the line side of the switch must be connected to ground.

## 5.7 Transfer Switch – “T” Option:

The transfer switch automatically switches between “Inverter mode” and “External power mode” depending of the external power line availability. External power 120 VAC, 60 Hz can be applied directly to the SPS AC input as explained in section 7.7.2.

## 5.8 Utility Vehicles – “U” Option:

SPS having the “U” option are designed for use on utility vehicle applications. The “U” option provides two AC output circuits; one circuit is GFCI protected and has a branch breaker. The second circuit (lead hardwires) is non-GFCI protected and has a 30A output breaker. All SPS having the “U” option come with a front panel On/Off switch (Figure 1, Item 1) and a LED Front Status Panel (Figure 5).

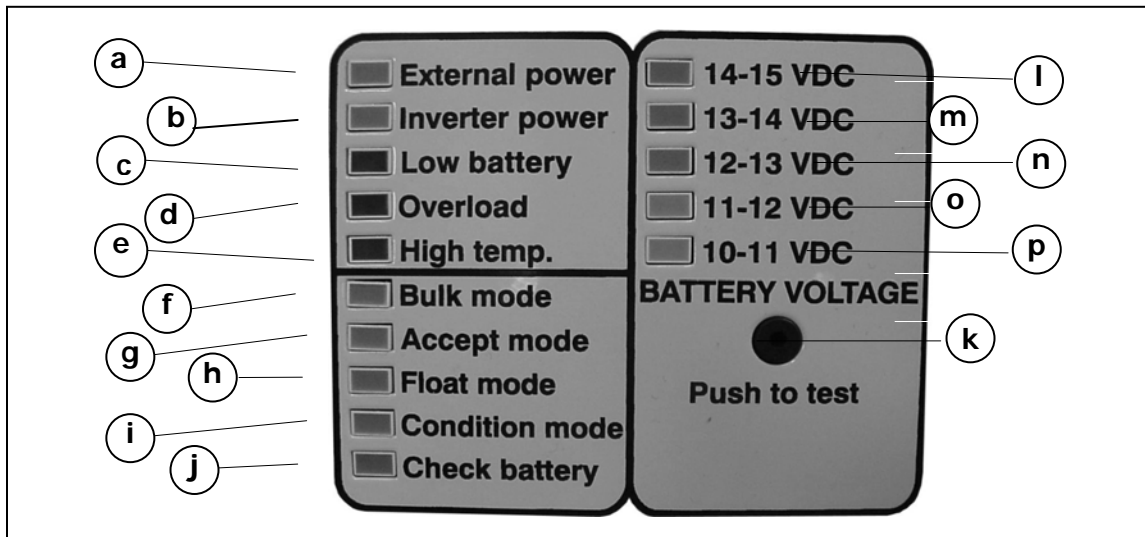

FIGURE 5: LED Front Status Panel – “U” Option



- (a) External power – “T” option: The green LED indicates that there is external 120 VAC, 60 Hz connected to the unit.
- (b) Inverter power: The green LED indicates that the SPS is operating from batteries in “inverter mode”.
- (c) Low battery: The red LED indicates that the SPS is in a low battery voltage condition.
- (d) Overload: The red LED indicates that the SPS is in an overload condition.
- (e) High temp: The red LED indicates that the SPS has a high internal temperature.
- (f) Bulk mode – “B3” option: The green LED indicates that the battery charger is in the bulk mode.
- (g) Accept mode – “B3” option: The green LED indicates that the battery charger is in the acceptance mode.
- (h) Float mode - “B3” option: The green LED indicates that the battery charger is in the float mode.
- (i) Condition mode - “B3” option: The green LED indicates that the battery charger is in the condition mode. Available with the “B3” option only.
- (j) Check battery - “B3” option: The yellow LED indicates a possible fault in the battery bank or DC cables.
- (k) Push to test – “U” option: Pressing this button enables the appropriate battery voltage LEDs as shown below.
- (l) 14 – 15 VDC (Battery voltage): Green LED.
- (m) 13 – 14 VDC (Battery voltage): Green LED.
- (n) 12 – 13 VDC (Battery voltage): Green LED.
- (o) 11 – 12 VDC (Battery voltage): Yellow LED.
- (p) 10 – 11 VDC (battery voltage): Yellow LED.

## 6 Installation

### 6.1 Tools for Installation:

Tools required for installation: Connectors (butt type and insulated), drill, Crimpers (for insulated and non-insulated connectors), volt meter with probes, electrical tape, straight screwdriver, #2 Phillips screwdriver, wire cutters, wire strippers, cable ties, tape measure.

### 6.2 System Components:

Picture	Model and Description	Qty.
	12U12 Options: A, B3, R2 & T	1
	Temp. Comp. Cable 611440-XX ("B3" option only) XX: Length of the cable in feet	1

### 6.3 Mounting the SPS:

	<i>The SPS mounting location should provide adequate ventilation and clearance to maintain room temperature during operation. At least 1/2 inch of clearance is required on all sides.</i>
-----------------------------------------------------------------------------------	--------------------------------------------------------------------------------------------------------------------------------------------------------------------------------------------

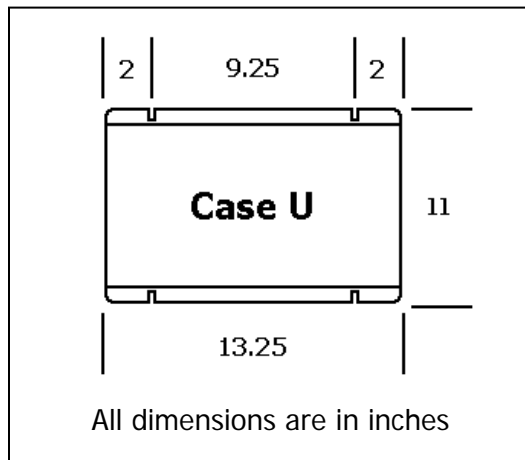

- Locate a suitable, secure vertical or horizontal mounting surface as close to the batteries as possible without being in the same airtight compartment.
- If mounting the SPS on a vertical surface, it is recommended that the front control panel be pointing down whenever possible.
- Locate the mounting holes on the chassis flanges and fasten them using 1/4 inch diameter screws to secure the SPS. See figure 6.

Figure 6: SPS footprints

**6.3.1 Chassis Bonding Lug:** Connect the bonding lug located at the right side of the SPS chassis to the earth grounding system using an 8-gauge copper wire.

**6.3.2 Temperature Compensation Probe:** If the battery charger "B3" option is included, connect the two-conductor wire to a negative post of the battery bank. Failure to connect the remote temperature sense probe correctly will result in improperly charged batteries.

## 7 SPS Wiring:

### 7.1 DC Wiring:

- 1 It is recommended in all cases to use stranded copper wires.
- 2 Use SGX cross-linked polyurethane insulation type that complies with the high temperature insulation requirements (125°C.) of SAE J-1127 and vehicle manufacturer requirements.
- 3 Wire gauge recommendations are minimum. For lower temperature rated, applications inside engine spaces or large motor loads and other applications with high surge currents use wire gauge 1 to 2 sizes larger than shown on table I.
- 4 Keep the wire runs between battery and SPS as short as possible.
- 5 Use Bussmann fuse type ANN-XXX and fuseblock # 3576 where XXX is the size of the fuse.

**7.1.1 Inverter Cable:** This is the cable that runs from the SPS module to the batteries. Estimate the "inverter cable" length and locate your SPS model on table I, cross-reference the wire gauge and fuse size.

Inverter Model	Full Load (Amps DC)	Inverter to battery estimated cable length in feet		
		1' – 10'	11' – 15'	16' – 20'
12U12	120	4-gauge, 200A fuse	2-gauge, 250A fuse	1-gauge, 300A fuse

**Table I:** Wire and Fusing Guide for 12VDC systems at 5% Voltage Drop at Full Output

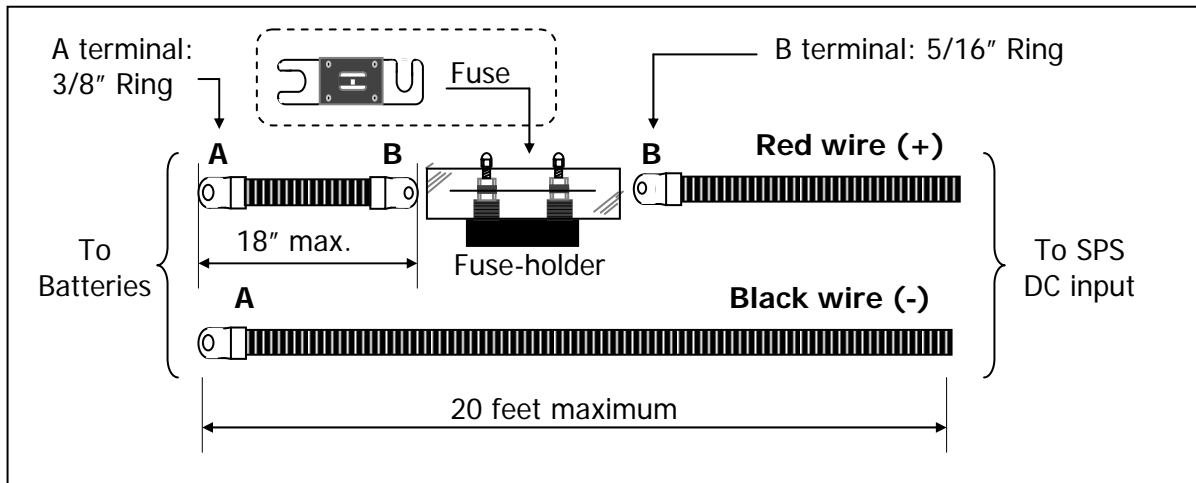

Figure 7: Inverter cable assembly

**7.1.2 Charge Cable:** This is the cable that runs from the batteries to vehicle alternator or OEM engine battery. Use 2-gauge cables and 250A fuse for small OEM alternators and 1/0-gauge and 350A for heavy-duty alternators.

### 7.1.3 Connecting the DC wires:



*Damage to the SPS not covered under warranty will occur if correct polarity is not observed when installing the DC input cables.*

- Refer to Figure 7: Inverter cable assembly and Figure 8: DC wiring diagram.
- Open the SPS field-wiring compartment to access the DC input lugs.
- Unscrew the DC input lug POS (+) and NEG (-) screws.
- Remove the fuse from the fuse holder for cable installation.
- Remove 3/4 inch of insulation from the un-terminated ends of the red and black cables.
- Insert the stripped end of the red wire into the DC input lug labeled POS (+) and the stripped end of the black wire into the DC input lug labeled NEG (-). Tighten the screws to 10 Ft. Lbs.
- Tighten the cover DC cable strain relief screws to 1 Ft. Lb.
- Connect the end of the short red cable to a POS (+) battery post.
- Connect the terminated end of the black cable (neg. return cable) directly to a battery NEG (-) post (DO NOT connect to the chassis).
- Install the in-line fuse in the fuse holder that is within 18" of the positive post of the battery bank (a one-time spark will occur when this final DC connection is made). To determine the fuse size, refer to section 7.1.1.

**7.1.4 Remote "On/Off" Switch:** An optional customer supplied "On/Off" switch may be connected to the SPS. The remote switch will operate only if the main "On/Off" switch on the face of the SPS is turned ON.

- Open the SPS field-wiring compartment to access the DC input connector.
- Locate the violet wire labeled "Remote Switch Hook-up" and remove it from the positive battery connector.
- Connect the violet wire to the load side of the "On/Off" remote switch.
- Using an 18-gauge wire, connect a fused (5 amp recommended) +12VDC battery voltage to the line side of the switch.
- The fuse should be mounted within 18 inches of the battery's positive post.
- All material used for the remote switch should be UL listed and installed per code.

**7.1.5 Remote "On/Off" Switch, Ground Start – "R2" Option:** An optional customer supplied "On/Off" switch may be connected to the SPS. The remote switch will operate only if the main "On/Off" switch on the face of the SPS is turned ON.

- Open the SPS field-wiring compartment to access the DC input connector.
- Locate the black wire labeled "Remote Switch Hook-up" and remove it from the negative battery connector.
- Connect the violet wire to the load side of the "On/Off" remote switch.
- Using an 18-gauge wire, connect the line side of the switch to ground.
- All material used for the remote switch should be UL listed and installed per code.

### 7.1.6 Deep Cycle Batteries:



*Do not use vehicle-starting batteries; deep discharge cycles typical with SPS applications can shorten the life of this type of batteries.*

- Install at least one auxiliary deep cycle battery to feed the SPS directly. Depending on the application running time more batteries could be added if necessary. The vehicle alternator will recharge the batteries.
- It is recommended to mount the battery bank close to the SPS. The maximum recommended distance between the SPS and the battery bank is 20 feet.
- The battery compartment must be vapor-tight to the interior of the vehicle and vented directly to the exterior.
- Install several vent-plugs within one inch of the top of the battery compartment to allow for ventilation. Install a ventilation assembly as needed.
- Allow space around the battery and especially above the battery for inspection, and maintenance purposes.
- The battery should not be able to move more than 1 inch in any direction.

## 7.2 AC Wiring:

Remove the SPS field-wiring compartment cover plate to access the 120VAC, 60Hz input and output hardwire leads and follow the color code connections: Hot - Black wire, Neutral - White wire, Ground - Green wire.

**7.2.1 AC Output:** The 120 VAC, 60 Hz current produced by the SPS is provided at the GFCI receptacle outlets located on front of the SPS ("A" and "U" options only). The output is also presented behind the wiring compartment panel for direct hardwire leads.

- If the option "A" is included, the hardwire leads are GFCI protected; therefore there is no need to install remote GFCI outlets.
- If the option "U" is included, the hardwire leads are not GFCI protected and must require the installation of remote GFCI outlets. The GFCI outlets model recommended is Hubbell # GFR 5352XX (20A) or GFR 5252XX (15A).
- If the "A" and "U" options are included together, the hardwire leads are GFCI protected; therefore there is no need to install remote GFCI outlets.



*Do not connect another source of AC power directly to the output of the SPS. This will result in damage to the SPS that is not covered under warranty.*

**7.2.2 AC Input:** If the transfer switch "T" option is included, the AC input hardwire leads can be connected to an external power line 120VAC, 60Hz outlet. The cable clamp strain relief should be used to secure the field wires. The input circuit should have a maximum 30 amps circuit protection from the distribution panel. If the input cable to the unit is 14-gauge, then a 15 amps circuit protection is required.

### 7.3 DC Wiring Diagram

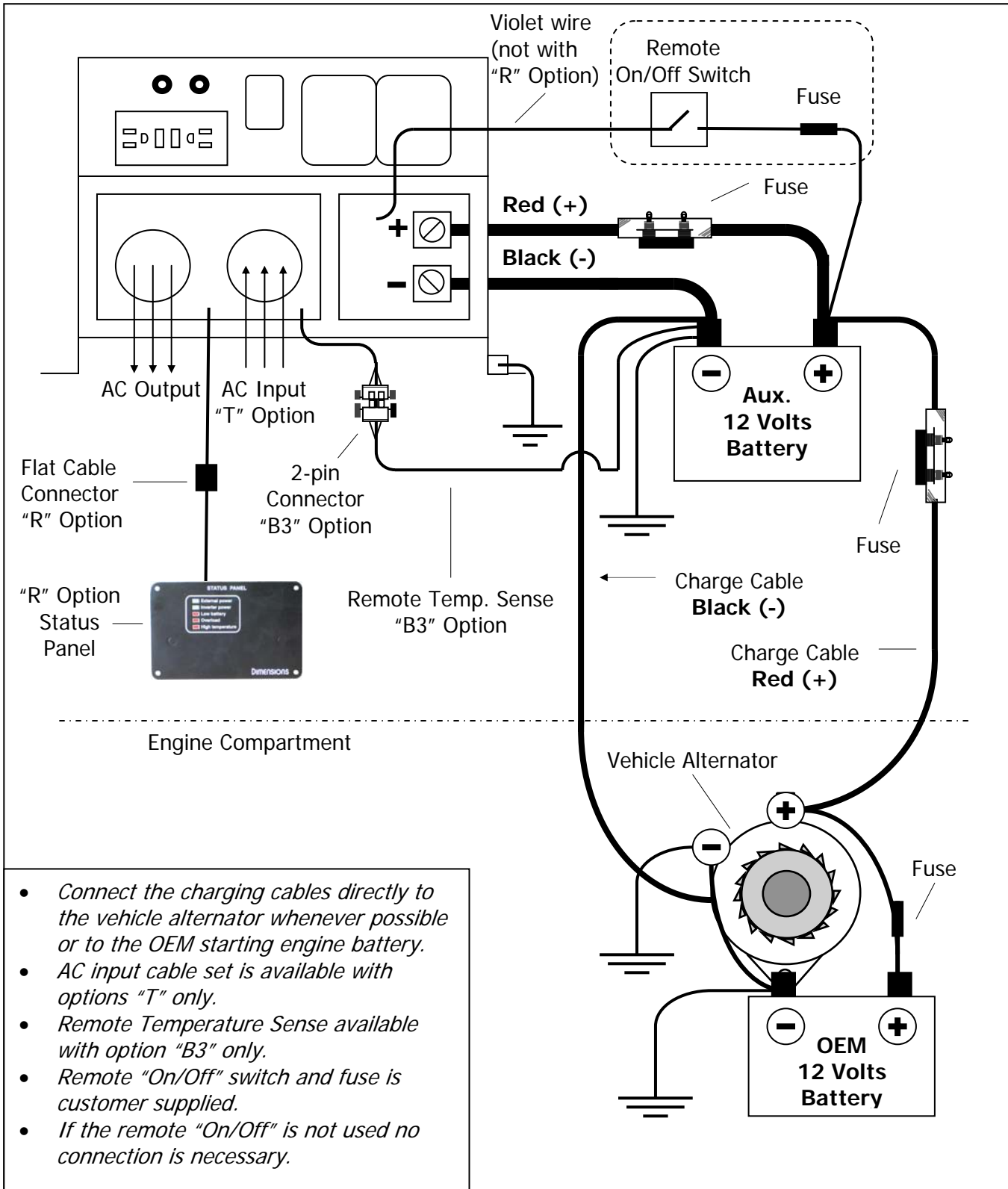

Figure 8a: DC wiring diagram

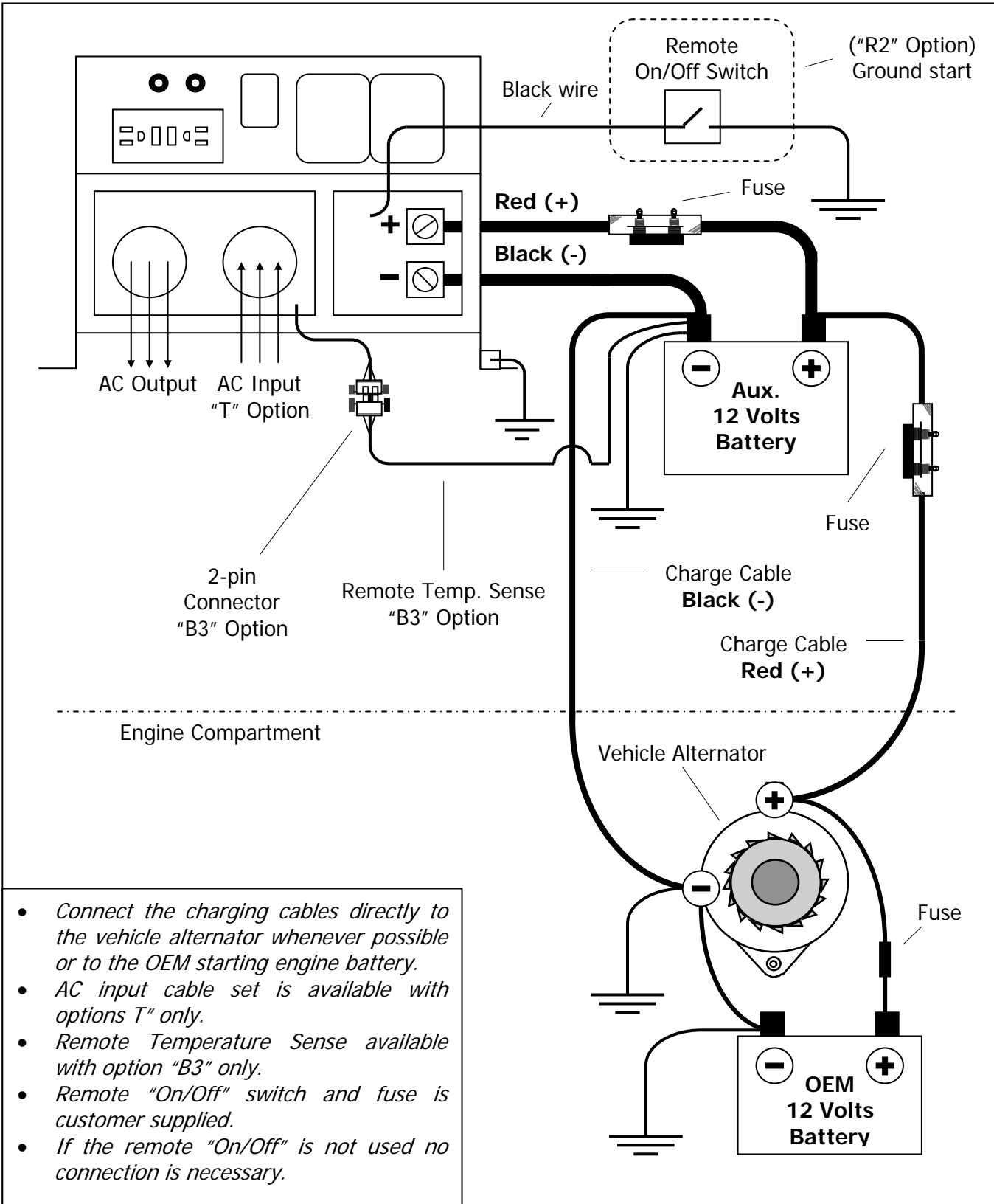

Figure 8b: DC wiring diagram – "R2" Option



## 7.4 AC Wiring Diagram

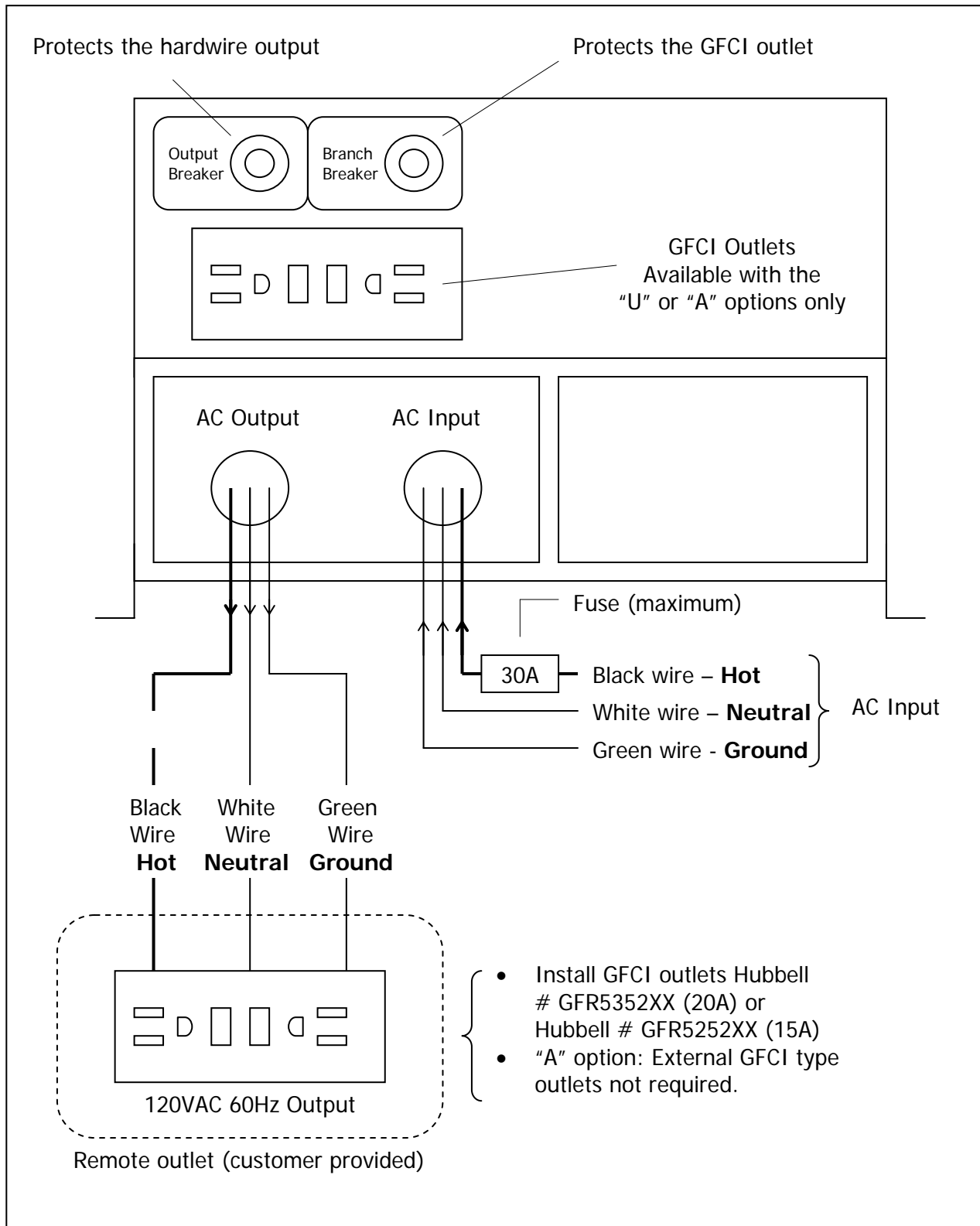



Figure 9: AC wiring diagram

## 8 Operation and Troubleshooting

### 8.1 Operation

	<i>The battery voltage must be higher than 9 volts for the SPS to operate.</i>
-----------------------------------------------------------------------------------	--------------------------------------------------------------------------------

**8.1.1 Setting the Battery Size and Type:** The battery selector switch located at the right side of the chassis must be set according to the type and size of the battery bank the SPS is connected to as shown in table II below.

**Table II:** Battery Selector Switch Position

BATTERY BANK SIZE (Amp-Hour)	DEEP CYCLE BATTERY TYPE	
	SEALED LEAD ACID	WET LEAD ACID
More than 200	A	C
Less than 200	B	D

**Table III:** Battery Charger Voltages

BATTERY TEMPERATURE		WET CELL BATTERIES			SEALED BATERIES		
		ACCEPT (Volts)	FLOAT (Volts)	CONDITIONING (Volts)	ACCEPT (Volts)	FLOAT (Volts)	CONDITIONING (Volts)
°F	°C						
78	25	14.6	13.2	14.9 to 15 max.	14.2	13.2	14.4 to 15 max.

**Table IV:** Battery Charger Time Periods

BATTERY BANK SIZE (Amp-Hour)	WET CELL TYPE BATTERIES			SEALED TYPE BATTERIES		
	BULK (max.)	ACCEPT (max.)	CONDITIONING (max.)	BULK (max.)	ACCEPT (max.)	CONDITIONING (max.)
Less than 200	6-hrs.	2-hrs.	3-hrs.	6-hrs.	2-hrs.	3-hrs.
Greater than 200	8-hrs.	3-hrs.	6-hrs.	8-hrs.	3-hrs.	4-hrs.

	<i>If the bulk mode times-out the charging process will go to the float mode immediately bypassing the acceptance mode.</i>
-------------------------------------------------------------------------------------	-----------------------------------------------------------------------------------------------------------------------------

**8.1.2 Turning the SPS "ON":** To turn the SPS ON, set the main switch to the "On" position. The green LED "Inverter Power" will come on. If the "T" option is included, the green LED "Inverter Power" will come only if no external power 120VAC 60 Hz is applied to SPS AC input, otherwise the green LED "External Power" LED will come on. If the remote switch is used, the inverter is turned ON or OFF by the remote switch.

	<i>Turn the SPS OFF if not in use. There is an approximated 1 to 2 amps DC draw from the batteries at idle or no load.</i>
-------------------------------------------------------------------------------------	----------------------------------------------------------------------------------------------------------------------------

## 8.2 Troubleshooting

Call or e-mail the Customer Service Department for a free consultation during business hours  
 8:00 a.m. to 5:00 p.m. (central time zone) at: 1-800-553-6418 or 1-651-653-7000;  
 fax: 1-651-653-7600; 1-888-439-3565; e-mail: [inverterinfo@sensata.com](mailto:inverterinfo@sensata.com)

- A TRUE RMS voltmeter is required for accurate AC output voltage readings on a quasi-sine SPS. A voltmeter that uses averaging circuitry will give a false reading.
- Unplug all loads and connect a 100-watt light bulb to the inverter output. Observe the LEDs light coming on at the control panel then check the troubleshooting table.

**Table V: Troubleshooting**

PROBLEM	POSSIBLE CAUSES OR SOLUTIONS
<b>No LEDs:</b> No power output. The SPS is not connected to the batteries; the battery voltage is below 9 volts DC or fault in the remote On/Off circuit.	Check the in-line fuses for continuity. Make sure the DC wires are clean and tight. Check the DC voltage at the SPS DC input. Check or bypass the remote On/Off circuit.
<b>Low battery:</b> Red LED indicator light. Indicates that the SPS has shut off due to a low battery voltage condition.	Fault in the battery wiring, battery capacity and voltage or the in-line fuse. This message will automatically clear or the SPS will shut off.
<b>Overload:</b> Red LED indicator light. Indicates that the SPS has shut off due to an overload condition.	The SPS output wiring is shorting or loads exceed the inverter rating. This message will automatically clear or the SPS will shut off. Remove the short circuit or excessive load from the output, and then switch the SPS off then on.
<b>High Temp:</b> Red LED indicator light on steady. Indicates that the SPS has shut off due to high internal temperature. The unit will automatically turn back on when it has cooled down to 40°C (104°F).  Red LED indicator light blinking. Indicates that the SPS has shut off due to high battery temperature 47°C – 50°C (117°F-122°F).	Verify that the SPS is in a vented compartment and that the fan is not blocked. High ambient temperatures combined with poor ventilation may also contribute to the shut down.  Battery compartment is too hot and needs to cool down. The charger will automatically turn back on when it has cooled down to 40°C (104°F)
<b>Overload &amp; High Temp:</b> Both of these red LED indicator lights are on steady. Indicates that the charger has shut off due to short or open temperature compensating sensor cable.	Temperature compensation sensor cable needs to be replaced.
<b>Check battery - "B3" Option:</b> Yellow LED indicator light. Indicates that the charger is operating in a low DC output voltage condition. The battery voltage must be higher than 9 volts for the charger to operate.	Shorted or defective battery. Make sure that the DC cable connections are tight and clean and not shorted, and that the proper wire gauge is used.
Indicates that the charger is operating in a high DC output voltage condition.	There is another source of battery charging or there is a defective battery charger. Disconnect and reconnect the external AC power to restart the battery charger.
Indicates that the SPS has shut off due to high battery voltage. The unit will automatically turn back on when the condition is removed.	Check battery wiring or remove other source of battery charging, such as the vehicle alternator.

## 9 Limited Warranty Terms & Conditions

**SHIPPING TERMS:** F.O.B. St. Paul Minnesota. Freight prepaid and billed, subject to prior credit approval.

**MINIMUM ORDER:** \$50.00 Net Price

**LOSS OR DAMAGE:** Loss or damage in transit are the responsibility of the carrier. Any claim should be filed with the delivering transport company. Invoice, Bill of Lading and Delivery receipt with damage noted therein must accompany any claims for freight damage. Claims for shortage and lost shipments must be made in writing to Sensata Technologies, Power Controls White Bear, St. Paul, MN within 10 days of date of shipment. Claims not reported within this time frame will not be honored.

**PRICES:** Prices are subject to change without notice. All orders are subject to acceptance at the factory. We reserve the right to invoice prices in effect at time of shipment.

**TERMS:** Net 30 days with approved credit, credit card or C.O.D.

**RETURN GOODS POLICY:**

- No returned materials will be accepted without an accompanying Returned Materials Authorization Number (RMA) from the factory.
  - Credit will be issued for returned goods to the original purchaser within 60 days of purchase, provided the inverter is returned to Sensata unused and not mounted. The amount of credit will be issued at Sensata's discretion based on the condition of the product.
  - Customer must be in good standing with Sensata Technologies.
  - Inverters that are discontinued, high-voltage (over 24vdc), special-order or used are excluded and will not be eligible for credit.
- Non-inverter items such as cable assemblies, fuses and fuse holders, will not be eligible for credit
- Support components supplied by Sensata vendors will be covered under that manufacturer's credit return policy.
  - Customer pays return freight.

**PLEASE SHIP AUTHORIZED RETURNS TO:**

Sensata Technologies RMA # \_\_\_\_\_ | Power Controls White Bear | 4467 White Bear Parkway | St. Paul, MN 55110  
Return Freight Prepaid

**LIMITED WARRANTY:**

Sensata Technologies extends the following warranty to the original purchaser of those goods subject to the qualifications indicated. Sensata warrants to the original purchaser for use that the goods or any component thereof manufactured by Sensata will be free from defects in workmanship from the date of purchase for the period listed on the product label, provided such goods are installed, maintained and used in accordance with Sensata and the original manufacturer's written instructions. Damages caused by the misuse, undue care or obvious wear through use will not be covered by this warranty.

Components not manufactured by Sensata, but used within the assembly provided by Sensata, are subject to the warranty period as specified by the individual manufacturer of said component, provided such goods are installed, maintained and used in accordance with Sensata and the manufacturer's written instructions.

Sensata's sole liability and the Purchaser's sole remedy for a failure of goods under this limited warranty and for any and all claims arising out of the purchase and use of the goods, shall be limited to the repair or replacement of the goods that do not conform to this warranty.

To obtain repair or replacement service under the limited warranty, the purchaser must contact the factory for a Return Material Authorization (RMA) number. Once obtained, send the Return Material Authorization Number along with the defective part or goods to: Sensata Technologies RMA # \_\_\_\_\_, Power Controls White Bear, 4467 White Bear Parkway, St. Paul, MN 55110.  
Return Freight Prepaid.

THERE ARE NO EXPRESS WARRANTIES COVERING THESE GOODS OTHER THAN AS SET FORTH ABOVE. THE IMPLIED WARRANTIES OF MERCHANTABILITY AND FITNESS FOR A PARTICULAR PURPOSE ARE LIMITED IN DURATION TO ONE YEAR FROM DATE OF PURCHASE.

SENSATA TECHNOLOGIES ASSUMES NO LIABILITY IN CONNECTION WITH THE INSTALLATION OR USE OF THE PRODUCT, EXCEPT AS STATED IN THIS LIMITED WARRANTY. SENSATA TECHNOLOGIES WILL IN NO EVENT BE LIABLE FOR INCIDENTAL OR CONSEQUENTIAL DAMAGES.

**WARNING: LIMITATIONS ON USE:** DIMENSIONS® brand products are not intended for use in connection with Life Support Systems and for Avionic use. Sensata Technologies makes no warranty or representation in connection with their products for such uses.